

E55

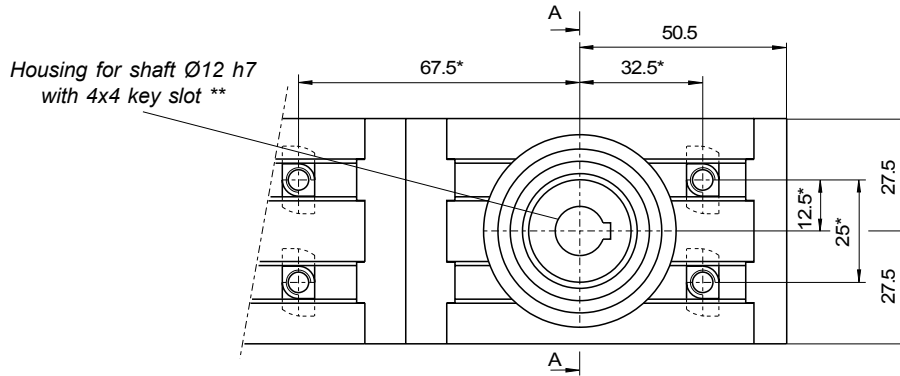

* Position of the T-nuts of our interface plates (see pages B32 and B33).

** In the inch versions (order code suffix "P"), the shaft housing is Ø1/2" with 1/8" x 1/8" keyslot.

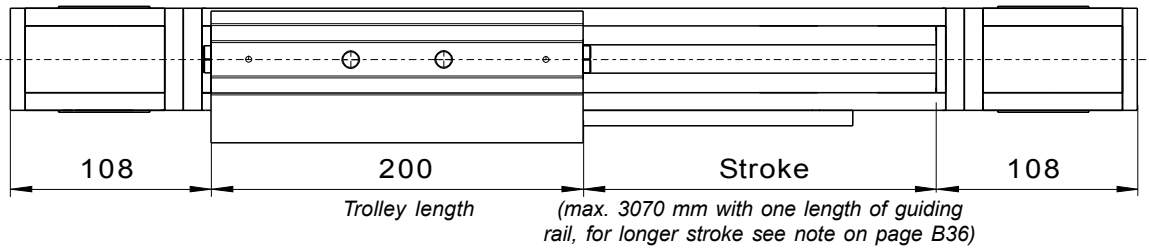
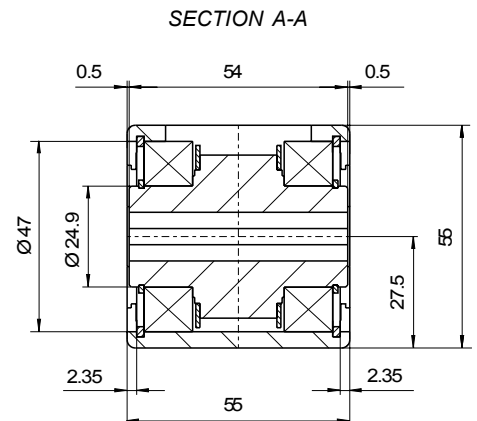
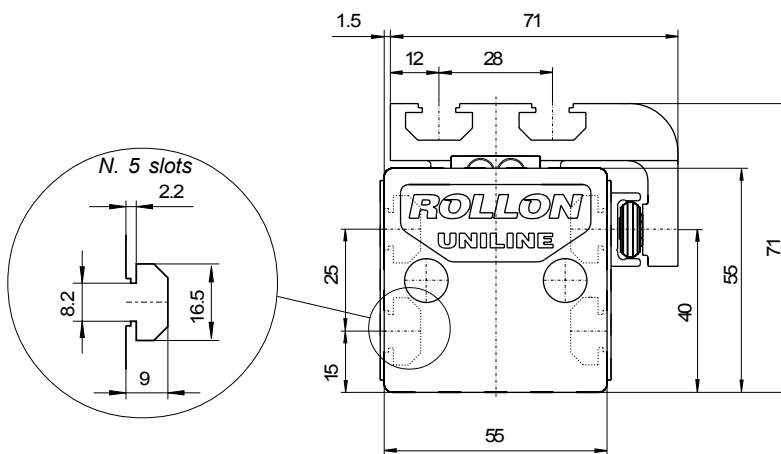

LOAD CAPACITIES

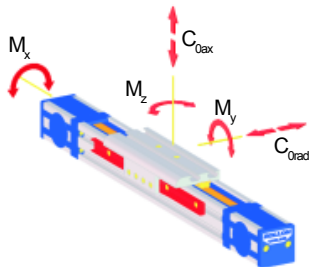

C0rad [N]	C0ax [N]	Mx [Nm]	My [Nm]	Mz [Nm]
2175	1500	25.5	43.4	54.4

Note: radial load C_{0rad} is considered to be applied along the axis of the internal rail (see page B5).

OTHER FEATURES

Moment of inertia I_y [cm ⁴]	34.6	Type of slider	CSW28 spec. 4 rollers / 4 CPA18
Moment of inertia I_z [cm ⁴]	41.7	Pitch diameter of pulley [m]	0.04138
Max speed [m/s]	3	Moment of inertia of mass of each pulley [gmm ²]	45633
Weight of unit with stroke zero [g]	3167	Mass of belt [g/m]	74
Weight of unit per meter [g]	5055	Max. Belt Tractive Force F_{max} [N]	1330
Mass of slider [g]	635	Standard belt tension [N]	220
Stroke for shaft revolution [mm]	130	Standard starting loadless torque [Nm]	0.3
Type of guiding rail	TLV28/ULV18	Belt length [m]	2 x stroke (in m)+ 0.630