

A75

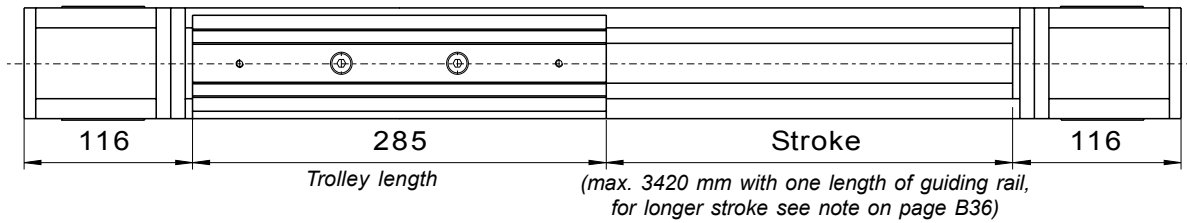

* Position of the T-nuts of our interfaces plates (see pages B32 and B33).

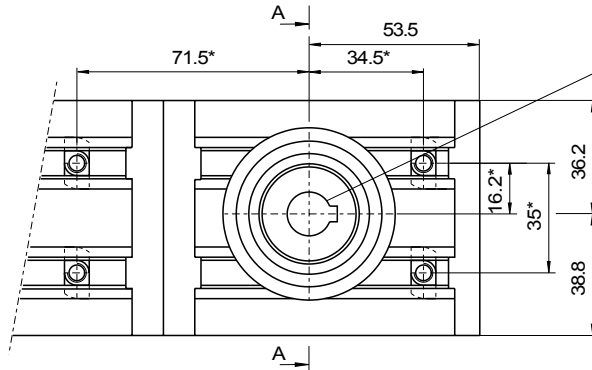

Housing for shaft Ø14 h7 with 5x5 key slot **

** In the inch versions (order code suffix "P"), the shaft housing is Ø5/8" with 3/16" x 3/16" key slot.

SPECIAL VERSIONS (upon request):

- Ø16 h7 with 5x5 keyway
- Ø19 h7 with 6x6 keyway
- Ø14 h7 for 14x18 compression coupling
- Ø19 h7 for 19x24 compression coupling

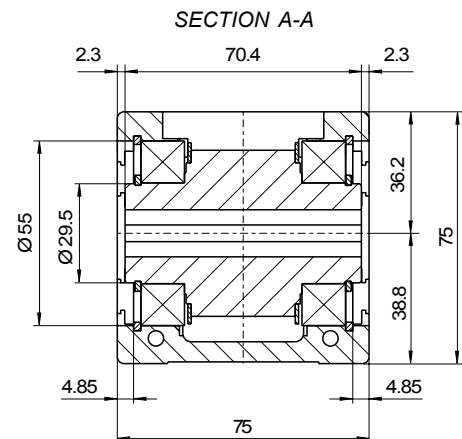
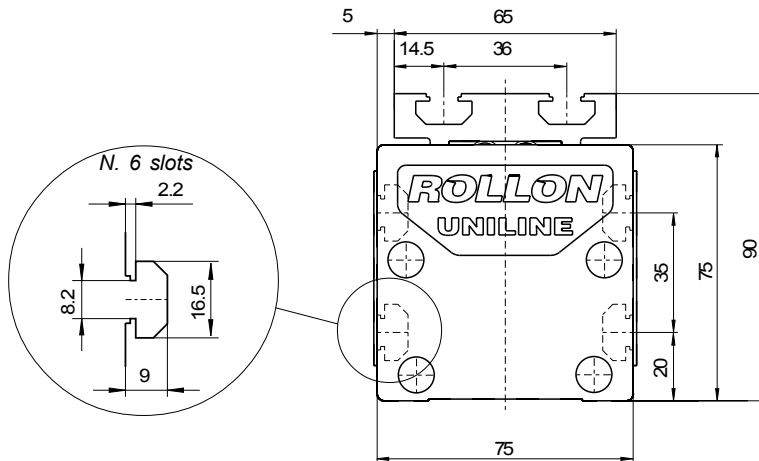

LOAD CAPACITIES

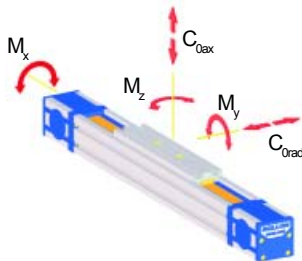

C0rad [N]	C0ax [N]	Mx [Nm]	My [Nm]	Mz [Nm]
5500	1855	43.6	81.5	209

Note: radial load C_{0rad} is considered to be applied along the axis of the internal rail (see page B5).

OTHER FEATURES

Moment of inertia I_y [cm ⁴]	127
Moment of inertia I_z [cm ⁴]	172
Max speed [m/s]	7
Weight of unit with stroke zero [g]	6729
Weight of unit per meter [g]	9751
Mass of slider [g]	1242
Stroke for shaft revolution [mm]	160
Type of guiding rail	TLV43

Type of slider	CSW43 spec. 4 rollers
Pitch diameter of pulley [m]	0.05093
Moment of inertia of mass of each pulley [gmm ²]	139969
Mass of belt [g/m]	185
Max. Belt Tractive Force F_{max} [N]	4480
Standard belt tension [N]	800
Standard starting loadless torque [Nm]	1.15
Belt length [m]	2 x stroke (in m) + 0.792