

6" Frame Brushless Servo Motors



Motor Data (Sine)

Motor Parameters	Units	421ASG****	1421BSG***	1422ASG****
Horsepower	Hp Rated	4.4	2.6	6.8
Kilowatts	KW Rated	3.2	2.1	5.1
Max. Operating Speed	N Max	2700	1750	2700
Speed @ Rated Torque	N Rated	2400	1500	2400
*Continuous Rated Torque @ Rated Speed	IN-LBS[Nm]	115.0[13.0]	120.0[13.5]	179.0[20.2]
*Continuous Stall Torque	IN-LBS[Nm]	130.0[14.7]	130.0[14.7]	210.0[23.7]
Continuous Line Current	AMPS(RMS ϕ)	11.6	6.9	18.7
Peak Torque	Tpk IN-LBS[Nm]	390.0[43.9]	390.0[43.9]	630.0[70.8]
Peak Current	AMPS(RMS ϕ)	33.9	20.9	56.3
Max. Theoretical Accel.	RAD/SEC ²	36,792	36,792	33,511
Torque Sensitivity	Kt IN-LBS/AMP (RMS ϕ)[Nm/AMP(RMS ϕ)]	11.2[1.26]	18.8[2.06]	11.2[1.26]
Back EMF (Line to Line)	$\pm 10\%$ Vrms/Krpm	70.0	115.0	70.0
D.C.Resistance (P-P)	$\pm 10\%$ OHMS	.66	1.7	.24
Inductance (P-P)	$\pm 10\%$ MILLIHENRIES	4.7	122	2.0
Rotor Inertia	Jm IN-LBS-SEC ² [Kg-M ²]	.0106 [.00119]	.0106 [.00119]	.0188 [.00212]
Static Friction	Tf IN-LBS[Nm]	2.4[0.27]	2.4[.27]	3.0[0.34]
Motor Weight	LBS[Kg]	36.0[16.3]	36.0[16.3]	51.0[23.1]
Line Voltage	VAC	230	230	230

Motor Parameters	Units	1422BSG****	1423ASG****	1423BSG****	1424ASG****	1424BSG****
Horsepower	Hp Rated	4.5	9.1	6.0	102	7.6
Kilowatts	KW Rated	3.4	6.8	4.5	7.6	5.7
Max. Operating Speed	N Max	1750	2700	1750	2400	1750
Speed @ Rated Torque	N Rated	1500	2400	1500	2100	1500
*Continuous Rated Torque @ Rated Speed	IN-LBS[Nm]	190.0[21.3]	238.0[26.9]	252.0[28.2]	306.0[34.6]	320.0[36.0]
*Continuous Stall Torque	IN-LBS[Nm]	210.0[23.7]	280.0[31.5]	280.0[31.5]	360.0[40.7]	360.0[40.7]
Continuous Line Current	AMPS(RMS/ ϕ)	11.2	25.0	14.9	24.0	19.2
Peak Torque	Tpk IN-LBS[Nm]	630.0[70.8]	840.0[94.4]	840.0[94.4]	1081.0[122.2]	1081.0[122.2]
Peak Current	AMPS(RMS/ ϕ)	33.5	75.2	44.7	72.1	57.5
Max. Theoretical Accel.	RAD/SEC ²	33,511	30,769	30,769	30,710	30,710
Torque Sensitivity	Kt IN-LBS/AMP (RMS ϕ)[Nm/AMP(RMS ϕ)]	18.2[2.06]	11.2[1.26]	18.2[2.06]	15.0[1.70]	18.2[2.06]
Back EMF (Line to Line)	$\pm 10\%$ Vrms/Krpm	115.0	70.0	115.0	93.0	115.0
D.C.Resistance (P-P)	$\pm 10\%$ OHMS	.72	.13	.45	.18	.26
Inductance (P-P)	$\pm 10\%$ MILLIHENRIES	6.1	1.4	4.3	1.7	2.9
Rotor Inertia	Jm IN-LBS-SEC ² [Kg-M ²]	.0188[.00212]	.0273[.00308]	.0273[.00308]	.0352[.00397]	.0352[.00397]
Static Friction	Tf IN-LBS[Nm]	3.0[0.34]	3.6[0.41]	3.6[0.41]	4.2[0.47]	4.2[0.47]
Motor Weight	LBS[Kg]	51.0[23.1]	66.0[29.9]	66.0[29.9]	83.0[37.7]	83.0[37.7]
Line Voltage	VAC	230	230	230	230	230

Brake Info:

Min. Holding Torque: 360IN-LBS
 Input Voltage: 24VDC
 Current: 1.13AMPS
 Inertia: .00227IN-LB-SEC²
 Weight Added: 12LBS

*25° C Ambient with a maximum case temperature of 100° C on motor. Motor mounted on a 12" x 12" x 1/2" aluminum heatsink. Thermostat in stator windings will open if winding temperature exceeds 155° C. This allows for an approximate +10% headroom in the continuous torque rating before thermostat opens.

- Mechanical Notes:
1. Axial Load: 50 LBS. Max.
 2. Radial Load: 150 LBS. Max. @ 1" from face
 3. Motor Sealed to IP65

Motor Data (Trap)

Motor Parameters		Units	1421ATG****	1421BTG****	1422ATG****	1422BTG****
Horsepower	Hp Rated	Hp	4.4	2.9	6.8	4.5
Kilowatts	KW Rated	KW	3.2	2.1	5.1	3.4
Max. Operating Speed	N Max	RPM	2700	1750	2700	1750
Speed @ Rated Torque	N Rated	RPM	2400	1500	2400	1500
*Continuous Rated Torque @ Rated Speed		IN-LBS[Nm]	115.0 [13.0]	120.0 [13.5]	179.0 [20.2]	190.0 [21.3]
*Continuous Stall Torque		IN-LBS[Nm]	130.0 [14.7]	130.0 [14.7]	210.0 [23.7]	210.0 [23.7]
Continuous Line Current		AMPS	16.9	9.8	26.5	15.8
Peak Torque	Tpk	IN-LBS[Nm]	390.0 [43.9]	390.0 [43.9]	630.0 [70.8]	630.0 [70.8]
Peak Current		AMPS	48.0	29.6	79.6	47.4
Max. Theoretical Accel.		RAD/SEC ²	36,792	36,792	33,511	33,511
Torque Sensitivity	Kt	IN-LBS/AMP[Nm/AMP]	7.9 [0.89]	12.9 [1.46]	7.9 [0.89]	12.9 [1.46]
Back EMF (Line to Line)	±10%	Vrms/Krpm	70.0	115.0	70.0	115.0
D. C. Resistance (P-P)	±10%	OHMS	.66	1.7	.24	.72
Inductance (P-P)	±10%	MILLIHENRIES	4.7	12.6	2.0	6.1
Rotor Inertia	Jm	IN-LBS-SEC ² [Kg-M ²]	.0106 [.00119]	.0106 [.00119]	.0188 [.00212]	.0188 [.00212]
Static Friction	Tf	IN-LBS[Nm]	2.4 [0.27]	2.4 [0.27]	3.0 [0.34]	3.0 [0.34]
Motor Weight		LBS[Kg]	36.0 [16.3]	36.0 [16.3]	51.0 [23.1]	51.0 [23.1]
Line Voltage		VAC	230	230	230	230

Motor Parameters		Units	1423ATG****	1423BTG****	1424ATG****	1424BTG****
Horsepower	Hp Rated	Hp	9.1	6.0	10.2	7.6
Kilowatts	KW Rated	KW	6.8	4.5	7.6	5.7
Max. Operating Speed	N Max	RPM	2700	1750	2400	1750
Speed @ Rated Torque	N Rated	RPM	2400	1500	2100	1500
*Continuous Rated Torque @ Rated Speed		IN-LBS[Nm]	238.0 [26.9]	252.0 [28.2]	306.0 [34.6]	320.0 [36.0]
*Continuous Stall Torque		IN-LBS[Nm]	280.0 [31.5]	280.0 [31.5]	360.0 [40.7]	360.0 [40.7]
Continuous Line Current		AMPS	35.4	21.1	34.0	27.1
Peak Torque	Tpk	IN-LBS[Nm]	840.0 [94.4]	840.0 [94.4]	1081.0 [122.2]	1081.0 [122.2]
Peak Current		AMPS	106.3	63.2	102.0	81.3
Max. Theoretical Accel.		RAD/SEC ²	30,769	30,769	30,710	30,710
Torque Sensitivity	Kt	IN-LBS/AMP[Nm/AMP]	7.9 [0.89]	12.9 [1.46]	10.4 [1.2]	12.9 [1.46]
Back EMF (Line to Line)	±10%	Vrms/Krpm	70.0	115.0	93.0	115.0
D. C. Resistance (P-P)	±10%	OHMS	.13	.45	.18	.26
Inductance (P-P)	±10%	MILLIHENRIES	1.4	4.3	1.7	2.9
Rotor Inertia	Jm	IN-LBS-SEC ² [Kg-M ²]	.0273 [.00308]	.0273 [.00308]	.0352 [.00397]	.0352 [.00397]
Static Friction	Tf	IN-LBS[Nm]	3.6 [0.41]	3.6 [0.41]	4.2 [0.47]	4.2 [0.47]
Motor Weight		LBS[Kg]	66.0 [29.9]	66.0 [29.9]	83.0 [37.7]	83.0 [37.7]
Line Voltage		VAC	230	230	230	230

Brake Info:

Min. Holding Torque: 360IN-LBS
 Input Voltage: 24VDC
 Current : 1.13AMPS
 Inertia : .00227IN-LB-SEC²
 Weight Added: 12LBS

*25° C Ambient with a maximum case temperature of 100° C on motor. Motor mounted on a 12" x 12" x 1/2" aluminum heatsink. Thermostat in stator windings will open if winding temperature exceeds 155° C. This allows for an approximate +10% headroom in the continuous torque rating before thermostat opens.

Mechanical Notes:

1. Axial Load: 50 LBS. Max.
2. Radial Load: 150 LBS. Max. @ 1" from face
3. Motor Sealed to IP65

Motor Data (Sine)

Motor Parameters		Units	1421CSJ****	1421DSJ****	1422CSJ****
Horsepower	Hp Rated	Hp	4.9	2.9	7.5
Kilowatts	KW Rated	KW	3.6	2.1	5.7
Max. Operating Speed	N Max	RPM	3400	1750	3400
Speed @ Rated Torque	N Rated	RPM	2800	1500	2800
*Continuous Rated Torque @ Rated Speed		IN-LBS[Nm]	110.0[12.4]	120.0[13.5]	170.0[19.2]
*Continuous Stall Torque		IN-LBS[Nm]	130.0[14.7]	130.0[14.7]	210.0[23.7]
Continuous Line Current		AMPS/(RMS/φ)	6.9	3.5	112
Peak Torque	Tpk	IN-LBS[Nm]	390.0[43.9]	390.0[43.9]	630.0[70.8]
Peak Current		AMPS/(RMS/φ)	20.9	10.5	335
Max. Theoretical Accel.		RAD/SEC ²	36,792	36,792	33,511
Torque Sensitivity	Kt	IN-LBS/AMP (RMS/φ)[Nm/AMP (RMS/φ)]	18.2[2.1]	36.5[4.1]	18.2[2.1]
Back EMF (Line to Line)	±10%	Vrms/Krpm	115.0	230.0	115.0
D.C. Resistance (P-P)	±10%	OHMS	1.9	7.1	.68
Inductance (P-P)	±10%	MILLIHENRIES	13.0	52.3	5.6
Rotor Inertia	Jm	IN-LBS-SEC ² [Kg-M ²]	.0106[.00119]	.0106[.00119]	.0188[.00212]
Static Friction	Tf	IN-LBS[Nm]	2.4[0.27]	2.4[0.27]	3.0[0.34]
Motor Weight		LBS[Kg]	36.0[16.3]	36.0[16.3]	51.0[23.1]
Line Voltage		VAC	460	460	460

Motor Parameters		Units	1422DSJ****	1423CSJ****	1423DSJ****	1424CSJ****	1424DSJ****
Horsepower	Hp Rated	Hp	4.5	9.8	6.0	124	7.6
Kilowatts	KW Rated	KW	3.4	7.3	4.5	9.3	5.7
Max. Operating Speed	N Max	RPM	1750	3400	1750	3400	1750
Speed @ Rated Torque	N Rated	RPM	1500	2800	1500	2800	1500
*Continuous Rated Torque @ Rated Speed		IN-LBS[Nm]	190.0[21.3]	220.0[24.8]	252.0[28.2]	280.0[31.6]	320.0[36.0]
*Continuous Stall Torque		IN-LBS[Nm]	210.0[23.7]	280.0[31.5]	280.0[31.5]	360.0[40.7]	360.0[40.7]
Continuous Line Current		AMPS/(RMS/φ)	5.6	14.9	7.5	192	9.6
Peak Torque	Tpk	IN-LBS[Nm]	630.0[70.8]	840.0[94.4]	840.0[94.4]	1081.0[122.2]	1081.0[122.2]
Peak Current		AMPS/(RMS/φ)	16.8	44.7	22.3	57.5	287
Max. Theoretical Accel.		RAD/SEC ²	33,511	30,769	30,769	30,710	30,710
Torque Sensitivity	Kt	IN-LBS/AMP (RMS/φ)[Nm/AMP (RMS/φ)]	36.5[4.1]	18.2[2.1]	36.5[4.1]	18.2[2.1]	36.5[4.1]
Back EMF (Line to Line)	±10%	Vrms/Krpm	230.0	115.0	230.0	115.0	2300
D.C. Resistance (P-P)	±10%	OHMS	2.5	.45	1.7	.26	1.2
Inductance (P-P)	±10%	MILLIHENRIES	230	4.3	16.9	2.9	11.1
Rotor Inertia	Jm	IN-LBS-SEC ² [Kg-M ²]	.0188[.00212]	.0273[.00308]	.0273[.00308]	.0352[.00397]	.0352[.00397]
Static Friction	Tf	IN-LBS[Nm]	3.0[0.34]	3.6[0.41]	3.6[0.41]	4.2[0.47]	4.2[0.47]
Motor Weight		BS[Kg]	51.0[23.1]	66.0[29.9]	66.0[29.9]	83.0[37.7]	83.0[37.7]
Line Voltage		VAC	460	460	460	460	460

Brake Info:

Min. Holding Torque: 360IN-LBS
 Input Voltage: 24VDC
 Current : 1.13AMPS
 Inertia : .00227IN-LB-SEC²
 Weight Added: 12LBS

*25° C Ambient with a maximum case temperature of 100° C on motor. Motor mounted on a 12" x 12" x 1/2" aluminum heatsink. Thermostat in stator windings will open if winding temperature exceeds 155° C. This allows for an approximate +10% headroom in the continuous torque rating before thermostat opens.

Mechanical Notes:

1. Axial Load: 50 LBS. Max.
2. Radial Load: 150 LBS. Max. @ 1" from face
3. Motor Sealed to IP65

Motor Data (Trap)

Motor Parameters		Units	1421CTJ****	1421DTJ****	1422CTJ****	1422DTJ****
Horsepower	Hp Rated	Hp	4.9	2.9	7.5	4.5
Kilowatts	KW Rated	KW	3.6	2.1	5.7	3.4
Max. Operating Speed	N Max	RPM	3400	1750	3400	1750
Speed @ Rated Torque	N Rated	RPM	2800	1500	2800	1500
*Continuous Rated Torque @ Rated Speed		IN-LBS[Nm]	110.0[12.4]	120.0[13.5]	170.0[19.2]	190.0[21.3]
*Continuous Stall Torque		IN-LBS[Nm]	130.0[14.7]	130.0[14.7]	210.0[23.7]	210.0[23.7]
Continuous Line Current		AMPS	9.8	4.9	15.8	7.9
Peak Torque	Tpk	IN-LBS[Nm]	390.0[43.9]	390.0[43.9]	630.0[70.8]	630.0[70.8]
Peak Current		AMPS	29.6	14.8	47.4	23.7
Max. Theoretical Accel.		RAD/SEC ²	36,792	36,792	33,511	33,511
Torque Sensitivity	Kt	IN-LBS/AMP[Nm/AMP]	12.9[1.46]	25.8[2.92]	12.9[1.46]	25.8[2.92]
Back EMF (Line to Line)	±10%	Vrms/Krpm	115.0	230.0	115.0	230.0
D.C.Resistance (P-P)	±10%	OHMS	1.9	7.1	.68	2.5
Inductance (P-P)	±10%	MILLIHENRIES	13.0	52.3	5.6	23.0
Rotor Inertia	Jm	IN-LBS-SEC ² [Kg-M ²]	.0106[.00119]	.0106[.00119]	.0188[.00212]	.0188[.00212]
Static Friction	Tf	IN-LBS[Nm]	2.4[0.27]	2.4[0.27]	3.0[0.34]	3.0[0.34]
Motor Weight		LBS[Kg]	36.0[16.3]	36.0[16.3]	51.0[23.1]	51.0[23.1]
Line Voltage		VAC	460	460	460	460

Motor Parameters		Units	1423CTJ****	1423DTJ****	1424CTJ****	1424DTJ****
Horsepower	Hp Rated	Hp	9.8	6.0	12.4	7.6
Kilowatts	KW Rated	KW	7.3	4.5	9.3	5.7
Max. Operating Speed	N Max	RPM	3400	1750	3400	1750
Speed @ Rated Torque	N Rated	RPM	2800	1500	2800	1500
*Continuous Rated Torque @ Rated Speed		IN-LBS[Nm]	220.0[24.8]	252.0[28.2]	280.0[31.6]	320.0[36.0]
*Continuous Stall Torque		IN-LBS[Nm]	280.0[31.5]	280.0[31.5]	360.0[40.7]	360.0[40.7]
Continuous Line Current		AMPS	21.1	10.6	27.1	13.6
Peak Torque	Tpk	IN-LBS[Nm]	840.0[94.4]	840.0[94.4]	1081.0[122.2]	1081.0[122.2]
Peak Current		AMPS	63.2	31.6	81.3	40.6
Max. Theoretical Accel.		RAD/SEC ²	30,769	30,769	30,710	30,710
Torque Sensitivity	Kt	IN-LBS/AMP[Nm/AMP]	12.9[1.46]	25.8[2.92]	12.9[1.46]	25.8[2.92]
Back EMF (Line to Line)	±10%	Vrms/Krpm	115.0	230.0	115.0	2300
D.C.Resistance (P-P)	±10%	OHMS	.45	1.7	.26	1.2
Inductance (P-P)	±10%	MILLIHENRIES	4.3	16.9	2.9	11.1
Rotor Inertia	Jm	IN-LBS-SEC ² [Kg-M ²]	.0273[.00308]	.0273[.00308]	.0352[.00397]	.0352[.00397]
Static Friction	Tf	IN-LBS[Nm]	3.6[0.41]	3.6[0.41]	4.2[0.47]	4.2[0.47]
Motor Weight		LBS[Kg]	66.0[29.9]	66.0[29.9]	83.0[37.7]	83.0[37.7]
Line Voltage		VAC	460	460	460	460

Brake Info:

Min. Holding Torque: 360IN-LBS
 Input Voltage: 24VDC
 Current: 1.13AMPS
 Inertia: .00227IN-LB-SEC²
 Weight Added: 12LBS

*25° C Ambient with a maximum case temperature of 100° C on motor. Motor mounted on a 12" x 12" x 1/2" aluminum heatsink. Thermostat in stator windings will open if winding temperature exceeds 155° C. This allows for an approximate +10% headroom in the continuous torque rating before thermostat opens.

- Mechanical Notes:
1. Axial Load: 50 LBS. Max.
 2. Radial Load: 150 LBS. Max. @ 1" from face
 3. Motor Sealed to IP65

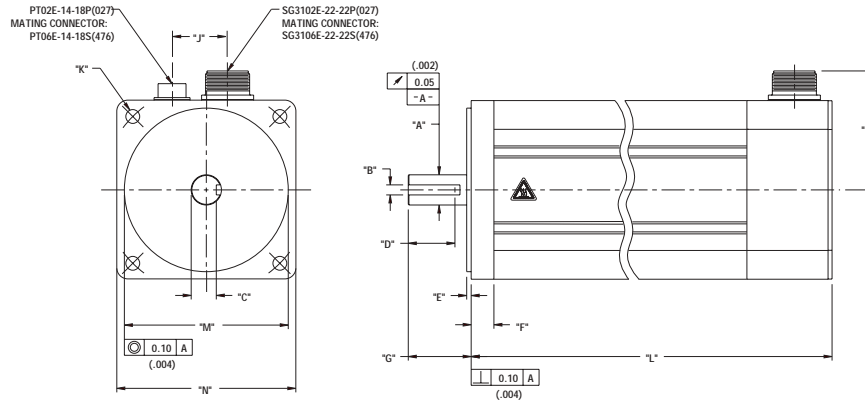

6" (142) English and Metric Connectorized Termination-Option 1 Motors

Model	"A"	"B"	"C"	"D"	"E"	"F"	"G"
MPM1421***6***	∅ .8750(22.225) .8745(22.212)	.1890(4.801) .1875(4.763)	.774(19.66)	1.41(35.8) Min	.13 (3.2)	.73 (18.4)	1.97 (50.0) 1.93 (49.0)
MPM1421***7***	∅ 24.000(9449) 23.988(9444)	7.998(3149) 7.963(3135)	19.91(.784)	37.0(1.46) Min	3.6 (.14)	18.0 (.71)	50.5 (1.99) 49.5 (1.95)
MPM1422***6***	∅ .8750(22.225) .8745(22.212)	.1890(4.801) .1875(4.763)	.774(19.66)	1.41(35.8) Min	.13 (3.2)	.73 (18.4)	1.97 (50.0) 1.93 (49.0)
MPM1422***7***	∅ 24.000(9449) 23.988(9444)	7.998(3149) 7.963(3135)	19.91(.784)	37.0(1.46) Min	3.6 (.14)	18.0 (.71)	50.5 (1.99) 49.5 (1.95)
MPM1423***6***	∅ .8750(22.225) .8745(22.212)	.1890(4.801) .1875(4.763)	.774(19.66)	1.41(35.8) Min	.13 (3.2)	.73 (18.4)	1.97 (50.0) 1.93 (49.0)
MPM1423***7***	∅ 31.999(1.2598) 31.986(1.2593)	10.000(.3937) 9.964(.3923)	26.90(1.059)	37.0(1.46) Min	3.6 (.14)	18.0 (.71)	50.5 (1.99) 49.5 (1.95)
MPM1424***6***	∅ .8750(22.225) .8745(22.212)	.1890(4.801) .1875(4.763)	.774(19.66)	1.41(35.8) Min	.13 (3.2)	.73 (18.4)	1.97 (50.0) 1.93 (49.0)
MPM1424***7***	∅ 31.999(1.2598) 31.986(1.2593)	10.000(.3937) 9.964(.3923)	26.90(1.059)	37.0(1.46) Min	3.6 (.14)	18.0 (.71)	50.5 (1.99) 49.5 (1.95)

Model	"H"	"J"	"K"	"L"	"L" w/ Brake	"M"	"N"
MPM1421***6***	3.7(95)Max	1.74(44.1)	3/8-16UNC-2BTHRU (4)EQ SPD AS SHOWN ON Ø5.875(149.22) B.C.	11.31(287.3)Max	14.01(355.9)Max	∅ 4.500(114.30) 4.499(114.27)	□ 5.59(142.0)
MPM1421***7***	95(3.7)Max	44.1(1.74)	∅11.00(.433)THRU (4)EQ SPD AS SHOWN ON Ø165.00(6.496) B.C.	286.8(11.29)Max	355.3(13.99)Max	∅ 130.00(5.118) 129.97(5.117)	□ 142.0(5.59)
MPM1422***6***	3.7(95)Max	1.74(44.1)	3/8-16UNC-2BTHRU (4)EQ SPD AS SHOWN ON Ø5.875(149.22) B.C.	14.01(355.9)Max	16.71(424.4)Max	∅ 4.500(114.30) 4.499(114.27)	□ 5.59(142.0)
MPM1422***7***	95(3.7)Max	44.1(1.74)	∅11.00(.433)THRU (4)EQ SPD AS SHOWN ON Ø165.00(6.496) B.C.	355.3(13.99)Max	423.9(16.69)Max	∅ 130.00(5.118) 129.97(5.117)	□ 142.0(5.59)
MPM1423***6***	3.7(95)Max	1.74(44.1)	3/8-16UNC-2BTHRU (4)EQ SPD AS SHOWN ON Ø5.875(149.22) B.C.	16.71(424.4)Max	19.41(493.0)Max	∅ 4.500(114.30) 4.499(114.27)	□ 5.59(142.0)
MPM1423***7***	95(3.7)Max	44.1(1.74)	∅11.00(.433)THRU (4)EQ SPD AS SHOWN ON Ø165.00(6.496) B.C.	423.9(16.69)Max	492.5(19.39)Max	∅ 130.00(5.118) 129.97(5.117)	□ 142.0(5.59)
MPM1424***6***	3.7(95)Max	1.74(44.1)	3/8-16UNC-2BTHRU (4)EQ SPD AS SHOWN ON Ø5.875(149.22) B.C.	19.41(493.0)Max	22.11(561.6)Max	∅ 4.500(114.30) 4.499(114.27)	□ 5.59(142.0)
MPM1424***7***	95(3.7)Max	44.1(1.74)	∅11.00(.433)THRU (4)EQ SPD AS SHOWN ON Ø165.00(6.496) B.C.	492.5(19.39)Max	561.1(22.09)Max	∅ 130.00(5.118) 129.97(5.117)	□ 142.0(5.59)

English = 6 Units: in (mm)
 Metric = 7 Units: mm (in)

For Mechanical Dimensions on Termination Option 2 Consult Factory.

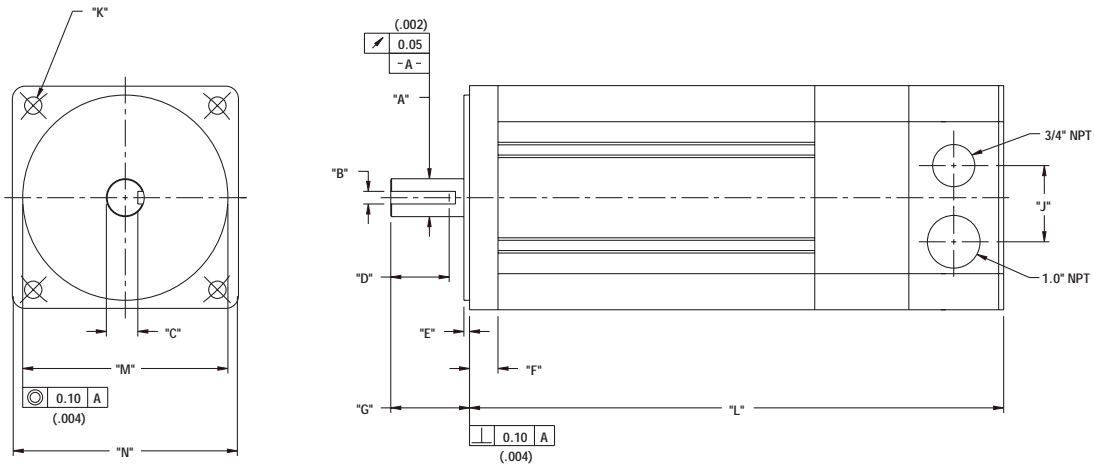

6" (142) English and Metric NPT Termination-Option 3 Motors

Model	"A"	"B"	"C"	"D"	"E"	"F"	"G"
MPM1421***6***	∅ .8750(22.225) ∅ .8745(22.212)	.1890(4.801) .1875(4.763)	.774(19.66)	1.41(35.8) Min	.13(3.2)	.73(18.4)	1.97(50.0) 1.93(49.0)
MPM1421***7***	∅ 24.00(9449) ∅ 23.988(9444)	7.998(3149) 7.963(3135)	19.91(.784)	37.0(1.46) Min	3.6(.14)	18.0(.71)	50.4(1.98) 49.4(1.94)
MPM1422***6***	∅ .8750(22.225) ∅ .8745(22.212)	.1890(4.801) .1875(4.763)	.774(19.66)	1.41(35.8) Min	.13(3.2)	.73(18.4)	1.97(50.0) 1.93(49.0)
MPM1422***7***	∅ 24.00(9449) ∅ 23.988(9444)	7.998(3149) 7.963(3135)	19.91(.784)	37.0(1.46) Min	3.6(.14)	18.0(.71)	50.4(1.98) 49.4(1.94)
MPM1423***6***	∅ .8750(22.225) ∅ .8745(22.212)	.1890(4.801) .1875(4.763)	.774(19.66)	1.41(35.8) Min	.13(3.2)	.73(18.4)	1.97(50.0) 1.93(49.0)
MPM1423***7***	∅ 31.999(1.2598) ∅ 31.986(1.2593)	10.000(.3937) 9.964(.3923)	26.90(1.059)	37.0(1.46) Min	3.6(.14)	18.0(.71)	50.4(1.98) 49.4(1.94)
MPM1424***6***	∅ .8750(22.225) ∅ .8745(22.212)	.1890(4.801) .1875(4.763)	.774(19.66)	1.41(35.8) Min	.13(3.2)	.73(18.4)	1.97(50.0) 1.93(49.0)
MPM1424***7***	∅ 31.999(1.2598) ∅ 31.986(1.2593)	10.000(.3937) 9.964(.3923)	26.90(1.059)	37.0(1.46) Min	3.6(.14)	18.0(.71)	50.4(1.98) 49.4(1.94)

Model	"J"	"K"	"L"	"L" w/ Brake	"M"	"N"
MPM1421***6***	1.90(48.3)	3/8-16UNC-2BTHRU (4)EQ SPD AS SHOWN ON ∅5.875(149.22) B.C.	13.37(339.6) Max	16.07(408.2) Max	∅ 4.500(114.30) ∅ 4.499(114.27)	□ 5.59(142.0)
MPM1421***7***	48.3(1.90)	∅11.00(.433)THRU (4)EQ SPD AS SHOWN ON ∅165.00(6.496) B.C.	339.0(13.35) Max	408.0(16.05) Max	∅ 130.00(5.118) ∅ 129.97(5.117)	□ 142.0(5.59)
MPM1422***6***	1.90(48.3)	3/8-16UNC-2BTHRU (4)EQ SPD AS SHOWN ON ∅5.875(149.22) B.C.	16.07(408.2) Max	18.77(476.8) Max	∅ 4.500(114.30) ∅ 4.499(114.27)	□ 5.59(142.0)
MPM1422***7***	48.3(1.90)	∅11.00(.433)THRU (4)EQ SPD AS SHOWN ON ∅165.00(6.496) B.C.	408.0(16.05) Max	477.0(18.75) Max	∅ 130.00(5.118) ∅ 129.97(5.117)	□ 142.0(5.59)
MPM1423***6***	1.90(48.3)	3/8-16UNC-2BTHRU (4)EQ SPD AS SHOWN ON ∅5.875(149.22) B.C.	18.77(476.8) Max	21.47(545.3) Max	∅ 4.500(114.30) ∅ 4.499(114.27)	□ 5.59(142.0)
MPM1423***7***	48.3(1.90)	∅11.00(.433)THRU (4)EQ SPD AS SHOWN ON ∅165.00(6.496) B.C.	477.0(18.75) Max	546.0(21.45) Max	∅ 130.00(5.118) ∅ 129.97(5.117)	□ 142.0(5.59)
MPM1424***6***	1.90(48.3)	3/8-16UNC-2BTHRU (4)EQ SPD AS SHOWN ON ∅5.875(149.22) B.C.	21.47(545.3) Max	24.17(613.9) Max	∅ 4.500(114.30) ∅ 4.499(114.27)	□ 5.59(142.0)
MPM1424***7***	48.3(1.90)	∅11.00(.433)THRU (4)EQ SPD AS SHOWN ON ∅165.00(6.496) B.C.	546.0(21.45) Max	613.3(24.15) Max	∅ 130.00(5.118) ∅ 129.97(5.117)	□ 142.0(5.59)

English = 6 Units: in (mm)
 Metric = 7 Units: mm (in)

For Mechanical Dimensions on Termination Option 2 Consult Factory.

6" Motor with Resolver Feedback

Option 1

Motor Connector 270-00017(SG3102E-22-22P(027))

Pin	Function
A	ϕ R
B	ϕ S
C	ϕ T
D	PE GND

Resolver Connector 270-00024(PT02E-14-18P(027))

Pin	Function
U	THERM
N	THERM
H	SIN
G	COS GND
S	COS
F	SIN GND
R	REF GND
E	REF
D	RES SHLD
P	GND
*A	BRK (+)
*B	BRK (-)
*C	BRK SHLD
J	-
K	-
L	-
M	-
T	-

*USE ONLY WITH BRAKE OPTION

Option 2

Motor Connector 270-00325 (CEGA258NN0000001000)

Pin	Function
U	ϕ R(U1)
V	ϕ S(V1)
W	ϕ T(W1)
PE	PE GND
*+	BRK (+)
*-	BRK (-)
1	THERM
2	THERM

*USE ONLY WITH BRAKE OPTION

Resolver Connector 270-00257(AEGA052NN00000013000)

Pin	Function
1	-
2	REF (R1)
3	REF GND (R2)
4	COS GND (S1)
5	COS (S3)
6	SIN (S2)
7	SIN GND (S4)
8	-
9	-
10	-
11	-
12	-

Option 3

Connection Chart (NPT) Resolver

Terminal	Function	Connection
1	ϕ R	TB3 (MOTOR CONN)
2	ϕ S	
3	ϕ T	
4	PE GND	
*S11	BRK (+)	TB2 (BRAKE CONN)
*S10	BRK (-)	
S9	REF GND	TB1 (RESOLVER & THERM CONN)
S8	REF	
S7	SIN	
S6	COS	
S5	COS GND	
S4	SIN GND	
S3	THERM	
S2	THERM	
S1	RES SHLD	

*USE ONLY WITH BRAKE OPTION

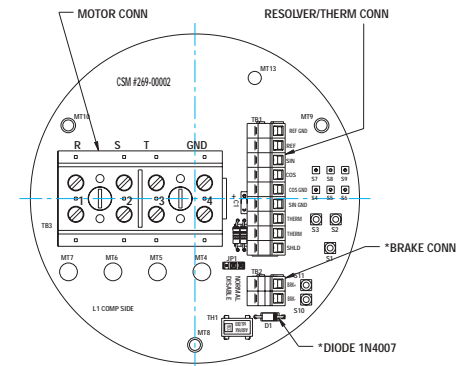



6" Motor with Encoder Feedback

Option 1

Motor Connector 270-00017 (SG3102E-22-22P(027))	
Pin	Function
A	ϕ R
B	ϕ S
C	ϕ T
D	PE GND



Encoder Connector 270-00024 (PT02E-14-18P(027))	
Pin	Function
T	GROUND
K	+5VDC
B	CH A
C	CH A\
N	CH B
P	CH B\
M	CH Z
U	CH Z\
E	CH U
R	CH U\
F	CH V
S	CH V\
G	CH W
H	CH W\
D	GND/CABLE
A	THERM
L	THERM
J	GND

Option 1 with brake

Encoder Brake Connector 270-00219 (PT02E-16-23P(027))	
Pin	Function
T	GROUND
K	+5VDC
B	CH A
C	CH A\
N	CH B
P	CH B\
M	CH Z
U	CH Z\
E	CH U
R	CH U\
F	CH V
S	CH V\
G	CH W
H	CH W\
D	GND/CABLE
A	THERM
L	THERM
J	GND
V*	BRK (+) 
W*	BRK (-) 
X*	BRK SHLD
Y	-
Z	-

* Use only with Brake option

Option 2

Motor Connector 270-00325 (CEGA258NN0000001000)	
Pin	Function
U	ϕ R(U1)
PE	PE GND
W	ϕ S(W1)
V	ϕ T(V1)
*+	BRK (+) 
*-	BRK (-) 
1	THERM
2	THERM

* USE ONLY WITH BRAKE OPTION

Motor Connector 270-00257 (AEGA052NN00000013000)	
Pin	Function
1	GND(OV)
2	CH A(A)
3	CH A(A\)
4	CH B(B)
5	CH B(B\)
6	CH Z(Z)
7	CH Z(Z\)
8	+5V(+5V)
9	-
10	CH U(RLG U)
11	CH V(RLG V)
12	CH W(RLG W)

Option 3-Consult Factory