

HLD60 with External Rail Specifications

Parameter	Value				Units
Configuration & Physical Parameters					
Motor	Animatics SM2315D, SM2315DT, SM2316D, SM2316DT, SM2337D or SM2337DT				-
Coupling	Flexible Jaw				-
Displacement/rev	2.5, 5, 10, 12.5				mm/rev
Position sensors	Optional Home & EOT limits				-
Stroke	100-600mm in 50mm steps 600-1000mm in 100mm steps 1000-4000mm in 200mm steps Custom lengths are available				mm
Overall length (L)	Stroke + 284				mm
Over-travel	26				mm
Unit mass	2.73 + 0.00441 x (stroke, mm) + (motor mass, kg)				kg
Performance					
Unidirectional repeatability	<20				µm
Bi-directional repeatability	60-180 (belt tension dependent)				µm
Accuracy *	0.5 per 300 stroke				mm/ mm
Displacement/rev	2.5	5	10	12.5	mm/rev
Linear speed @ 4200RPM	175	350	700	875	mm/s
Payload Mass**	45	42	18	13	kg
Continuous Thrust (Fa)					
SM2315D @ 48V @ 4500RPM	115	40	-	-	N
SM2315DT @ 48V @ 3300RPM	450	245	100	70	N
SM2316D @ 48V @ 4500RPM	270	120	35	-	N
SM2316DT @ 48V @ 3800RPM	450	420	185	135	N
SM2337D @ 48V @ 4500RPM	175	70	10	-	N
SM2337DT @ 48V @ 3200 RPM	450	290	125	90	N
Load Capacities, Dynamic ** (Static)					
Fb	730 (1200)	580 (1200)	460 (1200)	430 (1200)	N
Fc	730 (1200)	580 (1200)	460 (1200)	430 (1200)	N
Carriage moments, Dynamic ** (Static)					
M.a	19 (24)	15 (24)	12 (24)	11 (24)	Nm
M.b	72 (200)	57 (200)	45 (200)	42 (200)	Nm
M.c	72 (150)	57 (150)	45 (150)	42 (150)	Nm

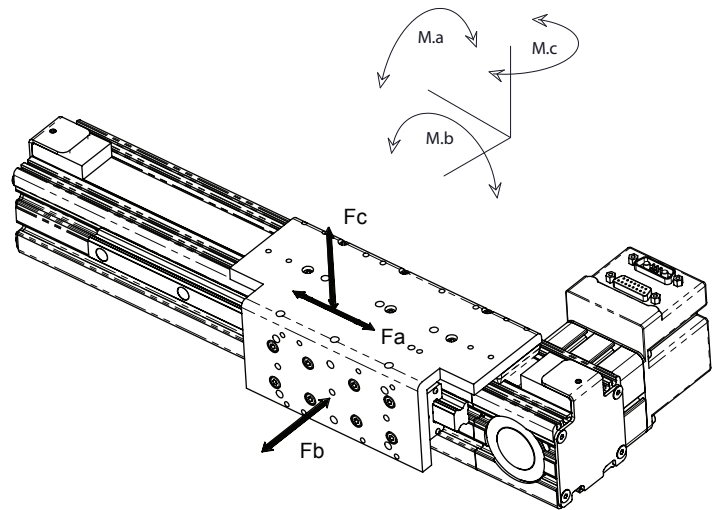
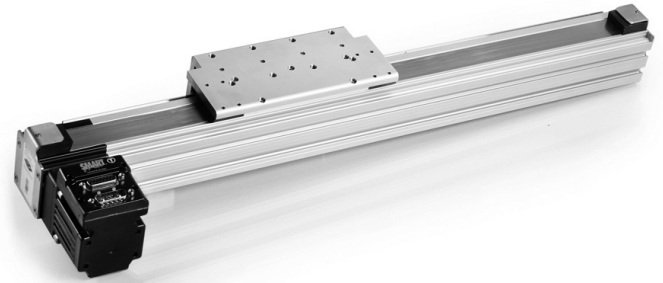

*Consult factory if greater accuracy is required

**Based on a 15000HR service life

@ 75/150/300 & 375mm/s (1800 RPM) average speed at given payload

Subject to routine lubrication

All OEM Dynamics™ Linear Integrated Systems are covered by Animatics patent #5,912,541 and other patents are in progress worldwide

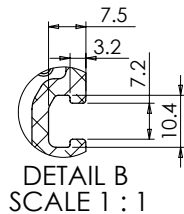
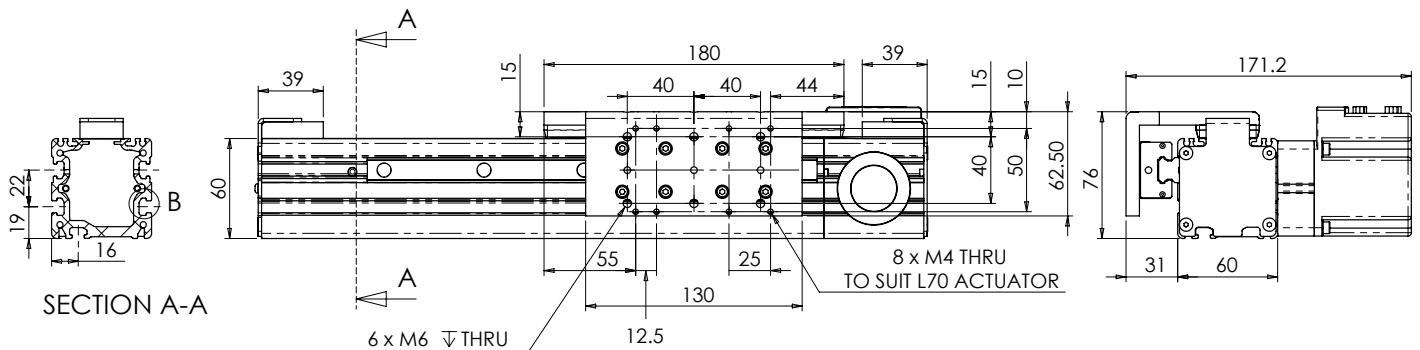
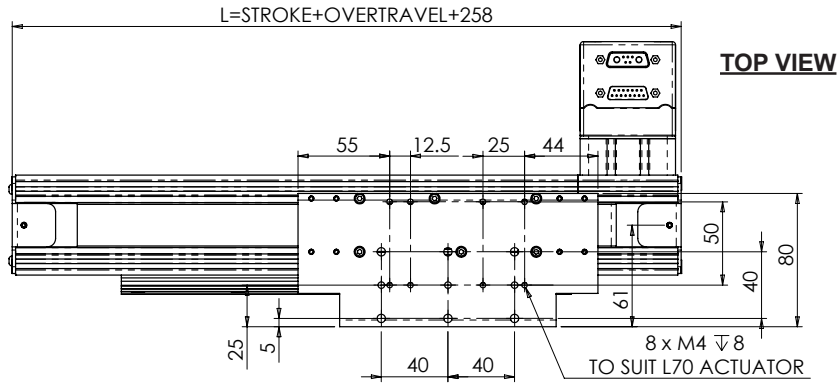

Dimensions in millimeters

Note: For part numbers please refer to our Website at www.oemdynamics.com/partnumbers or to catalog page 5.

Thrust Curve performance data in following section on pages 34-39.