

SERVO SYSTEMS CO.

Low Profile Series Linear Stages

Model: LPS-12-20

Description: 12 inch travel linear stage with anti-backlash lead-screw assembly, profiled linear rails, and four (two per rail) linear bearings

Motor Mount: Standard NEMA 23

Dimensions:

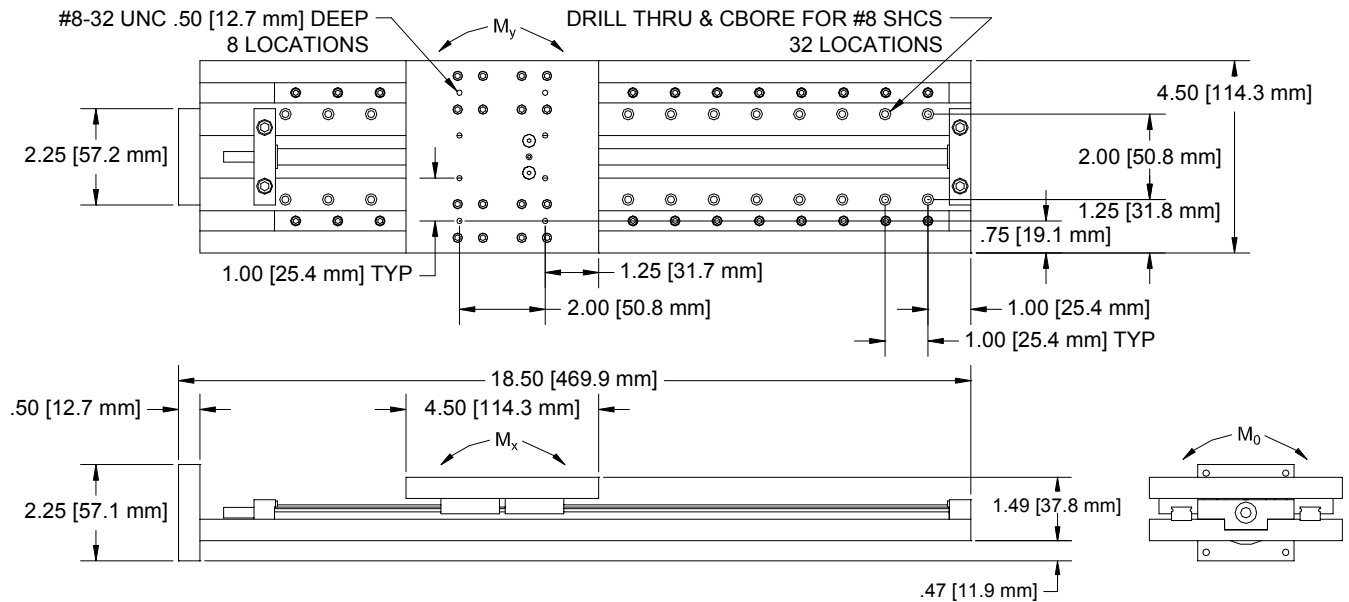

Specifications:

Unit Weight	6.3 lb.	Linear Speed	15 in./sec.
Moving Mass	1.312 lb.	Leadscrew Efficiency	81%
Travel Length	12.83 in.	Bidirectional Repeatability	0.0005 in.
Screw Inertia	1.631E-05 lb.-in.-sec. ²	Pricing Information	LPS-12-20*
Axial Moment (M_0)	180.50 in.-lb.	Optional Accessories	LPS-MFT* Mounting Foot LPS-xLS* Dual Position Limit / Home Sensors LPS-MCH* Manual Crank Handle LPS-MSH* Motor Shaft Crank Handle - fits 1/4" rear motor shaft LPS-ZB* Z-axis Bracket
Perpendicular Moments (M_x & M_y)	97.21 in.-lb.		
Maximum Dynamic Load	20 lb.		
Payload	18.688 lb.		
Drag Torque	3 oz.-in.		
Standard Lead	0.5 in./rev.		

Notes: Stock screw pitches come in 1 in., .5 in., .25 in., and .2 in.; other screw pitches available upon request
 *Contact Servo Systems Co. via phone or e-mail for pricing information

