



## FEATURES

- Highly Integrated, High Performance Microstepping Driver and Variable Speed Controller
- Advanced 2nd Generation Current Control for Exceptional Performance and Smoothness
- Single Supply: +12 to +48 VDC
- Low Cost
- Extremely Compact
- High Output Current up to 2 Amps RMS, 2.8 Amps Peak (Per Phase)
- 20 Microstep Resolutions up to 51,200 Steps Per Rev Including: Degrees, Metric, Arc Minutes
- 10-bit Analog Speed Control Input Accepts:
  - 0 to +5 VDC
  - 0 to +10 VDC
  - 4 to 20 mA
  - 0 to 20 mA
  - 15 to 25 kHz PWM
- Automatic Current Reduction
- Electronically Configurable:
  - Motor Run/Hold Current
  - Microstep Resolution
  - Acceleration/Deceleration
  - Initial and Max Velocity
  - Hold Current Delay Time/Motor Settling Delay Time
  - Programmable Filtering for the Stop/Start Input
- Setup Parameters May Be Switched On-The-Fly
- Power and Signal Interface Options:
  - Pluggable Terminal Strip
  - 12.0" (30.5cm) Flying Leads
- Graphical User Interface (GUI) for Quick and Easy Parameter Setup

## DESCRIPTION

The ultra compact Speed Control MForce MicroDrive offers system designers a low cost, high performance microstepping driver integrated with a variable speed controller.

The unsurpassed smoothness and performance delivered by MForce MicroDrives are achieved through IMS's advanced 2nd generation current control. By applying innovative techniques to control current flow through the motor, resonance is significantly dampened over the entire speed range and audible noise is reduced.

Speed Control MForce MicroDrives accept a broad input voltage range from +12 to +48 VDC, delivering enhanced performance and speed. Oversized input capacitors are used to minimize power line surges, reducing problems that can occur with long runs and multiple drive systems. An extended operating range of -40° to +85°C provides long life, trouble free service in demanding environments.

The high, per phase output current of up to 2 Amps RMS, 2.8 Amps Peak, allows the extremely compact MForce MicroDrive to control a broad array of motors from size 8 to size 34.

Speed Control MForce MicroDrives feature a digital oscillator for accurate velocity control with an output frequency of up to 5 Megahertz. Output frequency will vary with the signal applied to the speed control input and can be limited by the amount specified by the Maximum Velocity parameter.

Speed can be adjusted using three modes of operation: voltage, current and PWM. This allows control by a wide variety of sensors and devices.

There are two basic methods of controlling the velocity: bidirectional and unidirectional.

By moving the center point, both speed and direction are controlled by a potentiometer or joystick. By setting the center point to zero or the lower end of the potentiometer, only velocity is controlled by the speed control input; direction is controlled by a separate digital input.

The Speed Control MForce MicroDrive has 18 setup parameters, which may be configured using the supplied IMS Analog Speed Control GUI, or a user-developed front-end communication over SPI. The setup parameters enable the user to configure operational parameters which are stored in nonvolatile memory.

Power and signal interface connections are accomplished with either a pluggable terminal strip or 12.0" (30.5cm) flying leads. Motor phases are connected via a pluggable 4-pin locking wire crimp connector. Optional cables are available for ease of connecting and configuring the Speed Control MForce MicroDrive: a compact, powerful and inexpensive solution that will reduce system cost, design and assembly time for a large range of applications.

## CONFIGURING

The IMS Analog Speed Control is a software GUI for quick and easy parameter setup of the Speed Control MForce MicroDrive from a computer's USB port. GUI access is via the IMS SPI Motor Interface included on the CD shipped with the product, or from [www.imshome.com](http://www.imshome.com).

IMS Analog Speed Control features:

- Easy installation.
- Automatic detection of MForce version and communication configuration.
- Will not set out-of-range values.
- Tool-tips display valid range setting for each option.
- Simple screen interfaces.

# MForce MicroDrive – SPEED CONTROL

## STANDARD SPECIFICATIONS

<b>INPUT VOLTAGE (+V)</b>	Range	+12 to +48 VDC <i>Power supply current requirements = 2A (maximum) per MForce MicroDrive. Actual power supply current will depend on voltage and load.</i>	
	Input	0 to +5 VDC*, 0 to +10 VDC, 4 to 20 mA, 0 to 20 mA or 15 to 25 kHz PWM	
<b>SPEED CONTROL</b>	A/D Resolution	10 bit	
	RMS (Max)	2 Amps	
<b>OUTPUT CURRENT</b>	Peak (Per Phase)	2.8 Amps	
	Start/Stop and Direction	Low Level	0 to +0.8 VDC
High Level		+2.0 to +5.0 VDC	
Internal Pull-up Resistance (to +3.3 VDC)		20 kΩ	
<b>MOTION</b>	Oscillator Frequency (Max)	5 MHz	
	Microstep Resolution	Number of Settings	20
		Steps Per Revolution	200, 400, 800, 1000, 1600, 2000, 3200, 5000, 6400, 10000, 12800, 20000, 25000, 25600, 40000, 50000, 51200, 36000 (0.01 deg/μstep), 21600 (1 arc minute/μstep), 25400 (0.001mm/μstep)
<b>THERMAL</b>	Heat Sink Temperature	-40° to +85°C	

\*10 kΩ potentiometer resistance.

## SETUP PARAMETERS

	Function	Range	Units	Default
<b>A1</b>	Analog Input Mode	0 to +5 VDC, 0 to +10 VDC, 4 to 20 mA, 0 to 20 mA, 15 to 25 kHz PWM	—	0 to +5 VDC
<b>ACCL</b>	Acceleration	91 to 1.5 X 10 <sup>9</sup>	steps/second <sup>2</sup>	1,000,000
<b>C</b>	Joystick Center	1 to 1022	counts	0
<b>DB</b>	Analog Deadband	0 to 255	counts	1
<b>DECL</b>	Deceleration	91 to 1.5 X 10 <sup>9</sup>	steps/second <sup>2</sup>	1,000,000
<b>DIR</b>	Motor Direction Override	Clockwise (CW) / Counterclockwise (CCW)	—	CW
<b>FAULT</b>	Fault/Checksum Error	Error Code	—	None
<b>FS</b>	Analog Full Scale	1 to 1023	counts	1023
<b>HCDT</b>	Hold Current Delay Time	HCDT + MSDT <= 65535	milliseconds	500
<b>IF</b>	Analog Input Filter	1 to 1000	counts	1
<b>MHC</b>	Motor Hold Current	0 to 100	percent	5
<b>MRC</b>	Motor Run Current	1 to 100	percent	25
<b>MSDT</b>	Motor Settling Delay Time	MSDT + HCDT <= 65535	milliseconds	0
<b>MSEL</b>	Microstep Resolution	1, 2, 4, 5, 8, 10, 16, 25, 32, 50, 64, 100, 108, 125, 127, 128, 180, 200, 250, 256	μsteps per full step	256
<b>SSD</b>	Stop/Start Debounce	0 to 255	milliseconds	0
<b>VI</b>	Initial Velocity	0 to <VM	steps/second	1000
<b>VM</b>	Maximum Velocity	VI to 5,000,000	steps/second	768,000
<b>USER ID</b>	User ID	Customizable	1–3 characters	IMS

All parameters are set using the supplied IMS SPI Motor Interface GUI and may be changed on-the-fly. An optional Parameter Setup Cable is recommended with first orders.

## MOTOR RECOMMENDATIONS

IMS PART NUMBERS	Size 14 (0.75 Amps)	Size 17 (1.5 Amps)	Size 23 (2.4 Amps)
<b>SINGLE LENGTH</b>	M-1410-0.75	M-1713-1.5	M-2218-2.4
<b>DOUBLE LENGTH</b>	—	M-1715-1.5	M-2222-2.4
<b>TRIPLE LENGTH</b>	—	M-1719-1.5	M-2231-2.4

# MOTOR PERFORMANCE

## Speed-Torque

**Single Length 17 Motor** (IMS p/n M-1713-1.5)

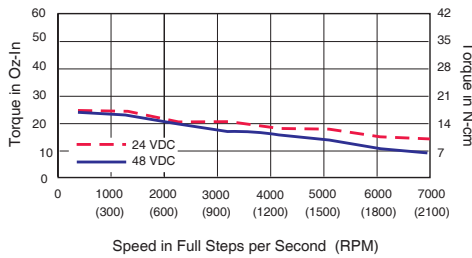

**Double Length 17 Motor** (IMS p/n M-1715-1.5)

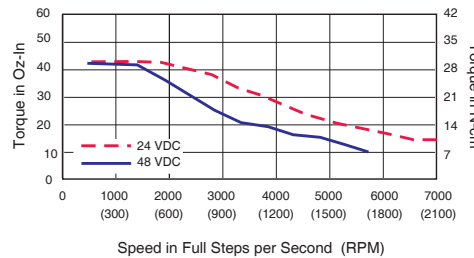

**Triple Length 17 Motor** (IMS p/n M-1719-1.5)

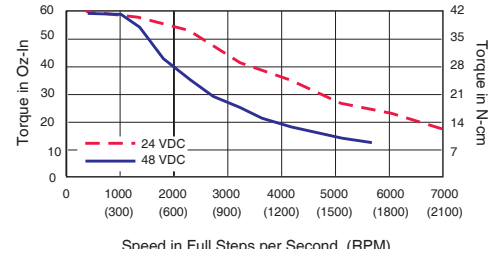

**Single Length 23 Motor** (IMS p/n M-2218-2.4)

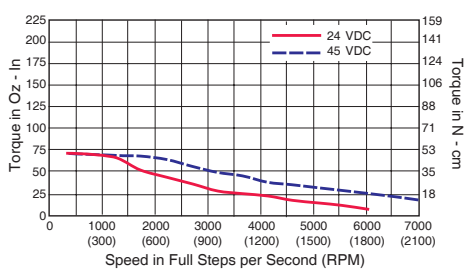

**Double Length 23 Motor** (IMS p/n M-2222-2.4)

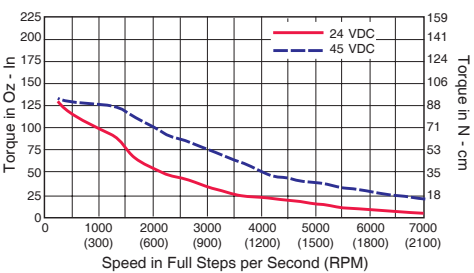

**Triple Length 23 Motor** (IMS p/n M-2231-2.4)

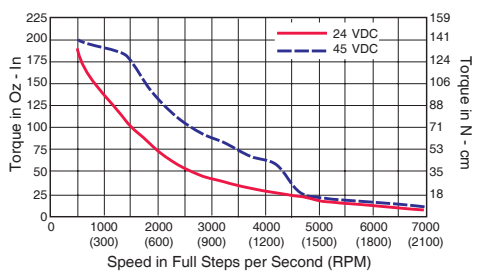

## PIN/WIRE ASSIGNMENTS

P1: I/O & POWER CONNECTOR		
Pluggable Terminal Strip	Flying Leads Wire Colors	Function
Pin 1	Violet	Start/Stop Input
Pin 2	Blue	CW/CCW Direction Input
Pin 3	Green	Speed Control Input
Pin 4	Yellow	+5 VDC Output
Pin 5	Gray	Logic Ground
Pin 6	Black	Power Ground
Pin 7	Red	+V (+12 to +48 VDC)

P2: COMM CONNECTOR		
10-Pin IDC	Wire Crimp	Function
Pin 1	Pin 9	No Connect
Pin 2	Pin 10	No Connect
Pin 3	Pin 7	No Connect
Pin 4	Pin 8	SPI Chip Select
Pin 5	Pin 5	Communications Ground
Pin 6	Pin 6	+5 VDC Output
Pin 7	Pin 3	SPI Master Out – Slave In
Pin 8	Pin 4	SPI Clock
Pin 9	Pin 1	No Connect
Pin 10	Pin 2	SPI Master In – Slave Out

P3: MOTOR CONNECTOR	
Pluggable Locking Wire Crimp	Function
Pin 1	Phase /A
Pin 2	Phase A
Pin 3	Phase /B
Pin 4	Phase B

## MECHANICAL SPECIFICATIONS

Dimensions in Inches (mm)

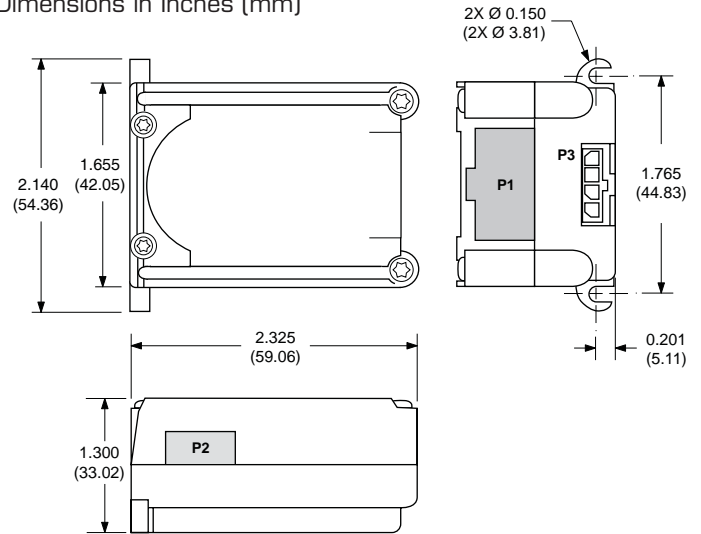

### P1 Connector Options

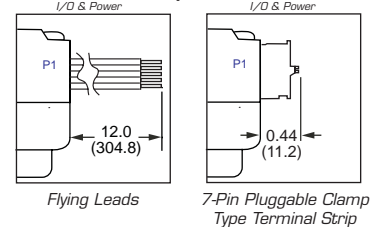

### P2 Connector Options

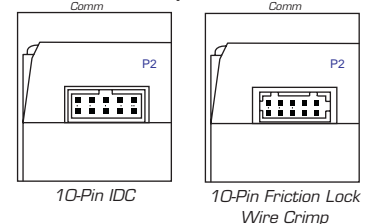

## OPTIONS

### Motors and Encoders

IMS offers a wide range of motors, encoders and accessories recommended for interface with the Speed Control MForce MicroDrive. For complete specifications on these products, please visit the IMS web site at [www.imshome.com](http://www.imshome.com).

### Power Supplies

IMS recommends the following power supplies for operating the MForce MicroDrive: IP402, IP404, ISP200-4. Complete power supply specifications at [www.imshome.com](http://www.imshome.com).

## ACCESSORIES

### Parameter Setup Cable and Adapter

The optional 12.0' (3.6m) parameter setup cable part number MD-CC300-000 facilitates communications interface and is recommended with first order. It connects the Speed Control MForce MicroDrive's P2 connector to a PC's USB port with pluggable mating connectors. MicroDrives with 10-pin friction lock wire crimp also require adapter MD-ADP-H.

### Prototype Development Cables

To speed prototyping, a 10.0' (3.0m) development cable PDO4-MF17-FL3 is available with locking pluggable wire crimp mate to the Motor Interface 4-pin Connector.

Accessories details at: [www.imshome.com/cables\\_cordsets.html](http://www.imshome.com/cables_cordsets.html)

## ORDER INFORMATION



**MFO1 S 17N4**

P1: I/O & Power  
F = 12" Flying Leads  
P = Pluggable Clamp Type Terminal Strip

P3: Motor Interface  
4-Pin Locking Wire Crimp

P2: Communications  
D = SPI with 10-Pin IDC Connector  
L = SPI with 10-Pin Friction Lock Wire Crimp Connector

**Example:** Part Number **MFO1PSD17N4** is a Speed Control MForce MicroDrive with pluggable I/O & power interface, SPI communications with 10-pin IDC connector and 4-pin motor interface.



## INTELLIGENT MOTION SYSTEMS, INC.

*Excellence in Motion™*

[www.imshome.com](http://www.imshome.com)

370 N. Main St., P.O. Box 457  
Marlborough, CT 06447 U.S.A.  
Phone: 860/295-6102  
Fax: 860/295-6107  
E-mail: [info@imshome.com](mailto:info@imshome.com)

**TECHNICAL SUPPORT (U.S.A.)**  
Phone: 860/295-6102  
Fax: 860/295-6107  
E-mail: [etech@imshome.com](mailto:etech@imshome.com)

**IMS ASIA PACIFIC OFFICE**  
30 Raffles Pl., 23-00 Caltex House  
Singapore 048622  
Phone: +65/6233/6846  
Fax: +65/6233/5044  
E-mail: [wlee@imshome.com](mailto:wlee@imshome.com)

**IMS EUROPEAN SALES MGT.**  
4 Quai Des Etroits  
69005 Lyon, France  
Phone: +33/4 7256 5113  
Fax: +33/4 7838 1537  
E-mail: [bmartinez@imshome.com](mailto:bmartinez@imshome.com)

**IMS UK Ltd.**  
25 Barnes Wallis Road  
Segensworth East  
Fareham, Hampshire PO15 5TT  
Phone: +44/0 1489-889825  
Fax: +44/0 1489-889857  
E-mail: [mcheckley@imshome.com](mailto:mcheckley@imshome.com)

### U.S.A. SALES OFFICES

#### Eastern Region

Phone: 973/661-1270  
Fax: 973/661-1275  
E-mail: [jroake@imshome.com](mailto:jroake@imshome.com)

#### Central Region

Phone: 260/402-6016  
Fax: 419/858-0375  
E-mail: [dwaksmann@imshome.com](mailto:dwaksmann@imshome.com)

#### Western Region

Phone: 602/578-7201  
E-mail: [dweisenberger@imshome.com](mailto:dweisenberger@imshome.com)

**DISTRIBUTED BY:**