

Series R45 Rotopulser®

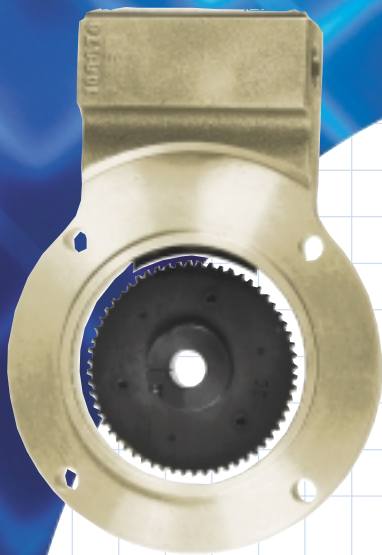

- **Direct mount to NEMA 56C through 184C AC or DC motors**
- **Field replaceable readhead for easy service**
- **Complete electrical protection and proven noise immunity**
- **Optional line driver outputs, screw terminal connections**
- **Thin profile – only 5/8" thick**

The Dynapar brand Series R45 Rotopulser® mounts directly to motors with a front or rear 4-1/2" NEMA C-face to provide digital feedback for RPM readout, speed control, and positioning. The separately mounted ring and gear are designed to function without any setup or adjustments. Operation is reliable even in wet, dirty, and extreme industrial temperature environments. No flexible shaft coupling is required, and there are no bearings to wear out, meaning greater mechanical reliability.

Coupled with a frequency-to-voltage converter, such as the Dynapar brand FV3, the R45 Rotopulser® provides a precise, brushless feedback, at a lower cost than expensive DC tachometer-generators.

An optional, X2 speed output provides twice the number of pulses per revolution for improved low speed operation. Line driver outputs are available for installations with long cable runs. A screw terminal option further simplifies field wiring.

The Series R45 contains other unique features not found in competitive units. The unique hub design uses a split collar clamp that provides better gear retention than set screws and will not raise burrs on the motor shaft which can make removal difficult. The Dynapar brand R45 is the thinnest package available, allowing more through shaft extension for clutches and brakes. The "overhung" conduit box allows mounting to the rear accessory flange of larger motors without mechanical interference.

The Series R45 Rotopulser® comes with all necessary mounting hardware included.

SPECIFICATIONS

Electrical

Code: Incremental

Resolution: 60 PPR (pulses/revolution), optional 120 PPR with X2 output

Format: Single channel unidirectional (A), or two channel quadrature (AB) outputs

Quadrature Phasing: $90^\circ \pm 45^\circ$ electrical

Symmetry: $180^\circ \pm 36^\circ$ electrical

Input Power: (not including output loads)
Single ended 4.5 min. to 16.5 VDC max. at 50 mA max.;

Open collector and differential line driver: 4.5 min. to 26 VDC max. at 75 mA max.

Outputs:

Single ended with 2 k Ω pullup: 16.5 VDC max., 20 mA sink at 0.5 V max.;

Open Collector: 30 VDC max., 40 mA sink max.;

7272 Differential Line Driver: 40 mA sink or source

Frequency Response: 10 kHz min.

Electrical Protection: Overvoltage and reverse voltage to 30 VDC; output short circuit protected to Common or other outputs, to +V (differential line driver only)

Noise Immunity: Tested to EN50082-2 (Heavy Industrial) for Electro Static Discharge, Radio Frequency Interference, Electrical Fast Transients, Conducted and Magnetic Interference

Terminations:

Wire leads: 7" long min., 18 AWG;

Screw terminals: accept 22 to 14 AWG solid or stranded wires

Mechanical

Motor frame sizes: 56C, 143TC, 145TC, 182C and 184C

Motor shaft/hub sizes: 5/8", 7/8" nominal

Housing: Cast Aluminum, chromate finish

Gear: 1010 Steel

Moment of Inertia: 0.0035 in-lb-sec²

Shaft Speed: 5,000 RPM max.

Readhead to gear gap: 0.020" nominal, 0.030 max.

Allowable Endplay: ± 0.060

Environmental

Operating Temperature: -40 to +85 °C

Storage Temperature: -40 to +90 °C

Shock: 20 G's for 11 milliseconds duration

Vibration: 5 to 2000 Hz at 2.5 G's

Humidity: to 98% without condensation

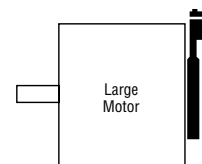
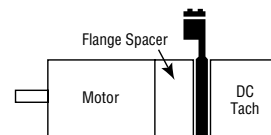
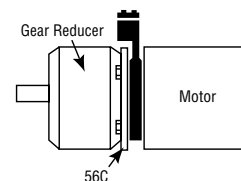

Outline Dimensions

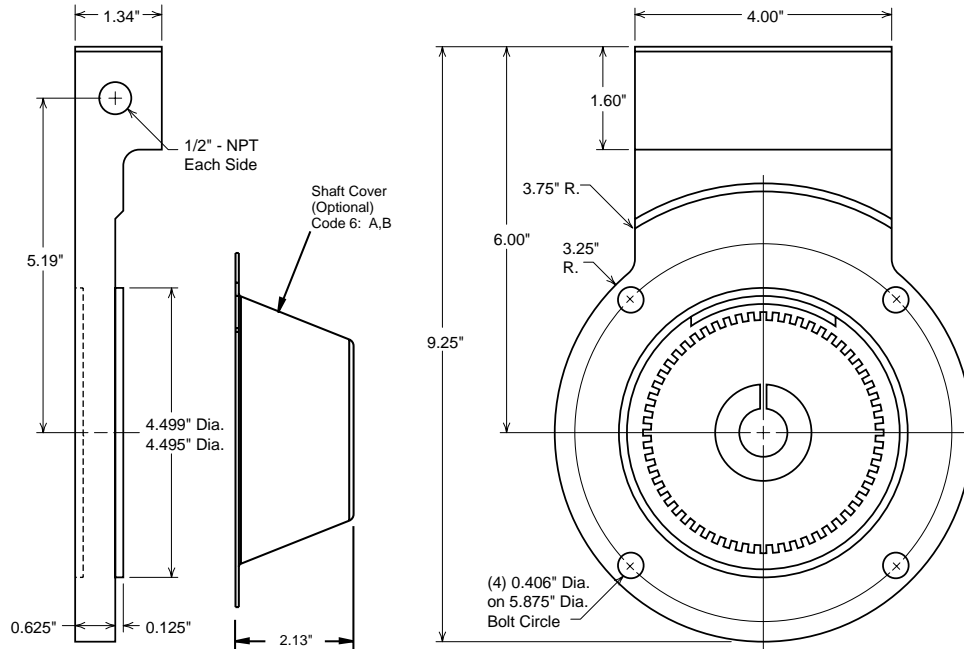

Electrical Connections

Function (If Used)	Wire Color	Terminal
Signal X2	ORG	1
Signal B	BRN	2
Signal A	YEL	3
+V in	RED	4
Common	BLK	5
Signal \bar{A}	WHT	6
Signal \bar{B}	GRN	7
Signal $\bar{X2}$	BLU	8

Ordering Information

To order, complete the model number with code numbers from the table below:

Code 1: Model	Code 2: PPR	Code 3: Gear, Bore	Code 4: Output	Code 5: Electrical	Code 6: Termination
R45	<input type="checkbox"/> <input type="checkbox"/> <input type="checkbox"/> <input type="checkbox"/>	<input type="checkbox"/>	<input type="checkbox"/>	<input type="checkbox"/>	<input type="checkbox"/>
Ordering Information					
R45 Motor Mount Ring, for NEMA 4-1/2" C-Face Motors	0060	0 no gear, readhead only 1 5/8" bore (56C) 2 7/8" bore (143TC, 145TC, 182C, 184C)	0 no readhead, gear only 1 single channel (A), unidirectional 2 dual channel (AB), bidirectional 3 dual channel (AB), bidirectional with unidirectional (X2) speed output	0 no readhead, gear only Available when Code 4 is 1, 2 or 3: 1 5-15V in, 5-15V single ended out 2 5-26V in, 5-26V differential line driver out 3 5-26V in, 5-26V open collector out	0 no readhead, gear only Available when Code 4 is 1, 2 or 3: 1 wire leads 2 screw terminals A Same as 1, with protective cover B Same as 2, with protective cover
R00 No Ring (gear or readhead only)					
112122-0001	R45 protective shaft cover accessory				

Example Model number: 5/8" bore, gear only = R00 0060 1000