

Hybrid Step Motors

SIZE 23

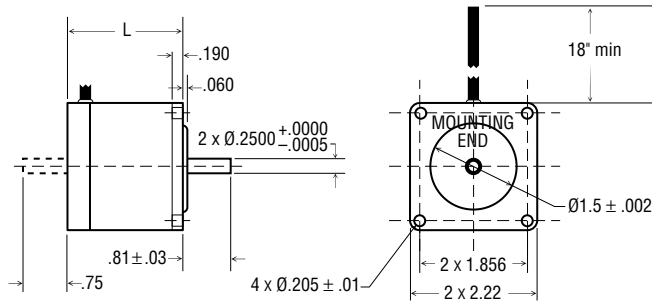

Part #	MOTOR CONNECTION 1 = series 2 = parallel 3 = unipolar	Motor Length (inches)	Minimum Holding Torque (oz-in)	Leads	Step Angle	Electrical				Rotor Inertia (oz-in ² /G-CM ²)	Motor Weight (Lbs.)
						Volts	Amps	Ohms	mH		
4023-839	1	1.5	49.5	6	1.8	8.5	0.71	12.0	20.0	.311/57	.80
	3	↓	35.0	↓	↓	6.0	1.00	6.0	5.0	↓	↓
5023-019	1	↓	56.6	↓	↓	18.7	0.31	60.0	112.0	↓	↓
	3	↓	40.0	↓	↓	13.2	0.44	30.0	28.0	↓	↓
4023-819	1	2.0	74.9	↓	↓	7.2	0.71	10.2	40.0	.547/100	1.17
	3	↓	53.0	↓	↓	5.1	1.00	5.1	10.0	↓	↓
4023.820	1	↓	74.9	↓	↓	1.8	2.76	0.7	1.4	↓	↓
	3	↓	53.0	↓	↓	1.3	3.90	0.33	0.35	↓	↓
4023-823	1	↓	74.9	↓	↓	15.6	0.31	50.0	152.0	↓	↓
	3	↓	53.0	↓	↓	11.0	0.44	25.0	38.0	↓	↓
4023-998	1	↓	74.9	↓	↓	33.9	0.21	160.0	328.0	↓	↓
	3	↓	53.0	↓	↓	24.0	0.30	80.0	82.0	↓	↓
5023-100	2	↓	81.0	4	↓	3.2	2.00	1.6	5.0	↓	↓
* 5023-122	1	↓	96.6	8	↓	4.9	0.99	5.0	17.2	↓	↓
	2	↓	96.6	↓	↓	2.5	1.98	1.3	4.3	↓	↓
	3	↓	69.0	↓	↓	3.5	1.40	2.5	4.3	↓	↓
5023-196	1	↓	113.0	6	↓	18.7	0.42	44.0	128.0	↓	↓
	3	↓	80.0	↓	↓	13.2	0.60	22.0	32.0	↓	↓
5023-094	1	2.25	117.0	↓	↓	8.5	0.85	10.0	23.0	.79/144	1.20
	3	↓	83.0	↓	↓	6.0	1.20	5.0	8.0	↓	↓

OTHER LENGTHS AND WINDINGS AVAILABLE UPON REQUEST

• Part numbers listed are for single shaft. To order double shaft add 'D' to the end.

* Optimized for microstepping and use with 160 volt drives.

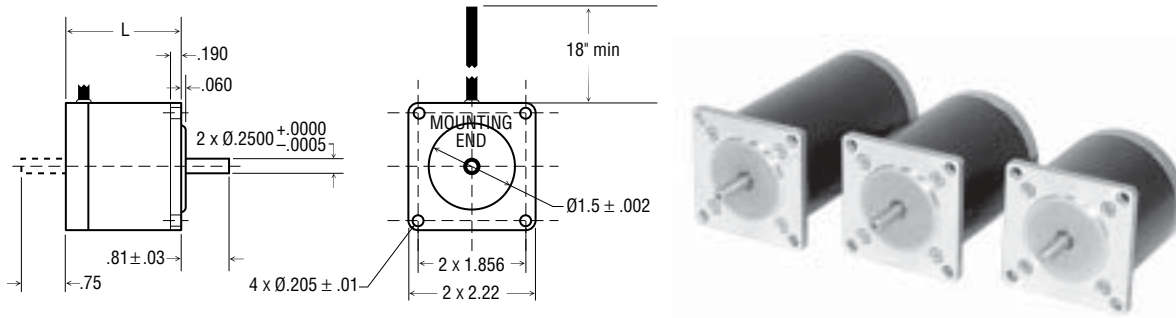

Part #	MOTOR CONNECTION			Motor Length (inches)	Minimum Holding Torque (oz-in)	Leads	Step Angle					Rotor Inertia (oz-in ² /G-CM ²)	Motor Weight (Lbs.)
	1 = series	2 = parallel	3 = unipolar					Volts	Amps	Ohms	mH		
5023-499		2		2.25	110.0	4	1.8	3.3	2.00	1.7	5.0	.79/144	1.20
4023-828		1		3.0	141.0	6		2.7	3.32	0.8	2.0	1.28/234	2.00
			3		100.0			1.9	4.70	0.4	0.5		
4023-830		1			141.0			6.6	1.27	5.2	20.0		
			3		100.0			4.7	1.80	2.6	5.0		
5023-024		1			141.1			7.6	1.06	7.2	27.9		
			3		100.0			5.4	1.50	3.6	6.9		
* 5023-123		1			158.0	8		5.9	1.26	4.6	18.8	1.14/210	
			2		158.0			3.0	2.52	1.2	4.7		
			3		112.0			4.2	1.78	2.3	4.7		
5023-149		1		3.25	198.0			5.1	1.41	3.6	16.0	1.19/219	2.12
			2		198.0			2.5	2.83	0.9	4.0		
			3		140.0			3.6	2.00	1.8	4.0		
4023-833		1		4.0	212.0	6		3.1	3.25	1.1	3.2	1.76/322	2.80
			3		150.0			2.2	4.60	0.48	0.8		
4023-835		1			212.0			4.8	2.05	2.30	9.2		
			3		150.0			3.4	2.90	1.16	2.3		
* 5023-124		1			224.0	8		5.7	1.75	3.3	16.8	1.72/315	
			2		224.0			2.8	3.49	0.8	4.2		
			3		160.0			4.0	2.47	1.63	4.2		

OTHER LENGTHS AND WINDINGS AVAILABLE UPON REQUEST

- Part numbers listed are for single shaft. To order double shaft add 'D' to the end.
- *Optimized for microstepping and use with 160 volt drives.