

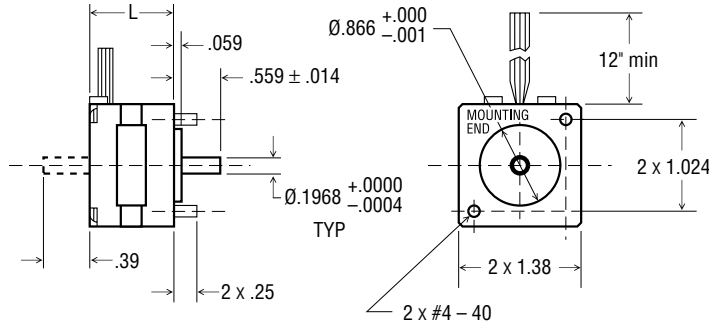

Hybrid Step Motors

SIZE
14



Part #	MOTOR CONNECTION 1 = series 2 = parallel 3 = unipolar	Motor Length (inches)	Minimum Holding Torque (oz-in)	Leads	Step Angle	Electrical				Rotor Inertia (oz-in ² /G-CM ²)	Motor Weight (Lbs.)
						Volts	Amps	Ohms	mH		
5014-820	2	1.00	8.0	4	1.8	3.2	.35	8.5	8.0	.051/9.3	.33
5014-842	2	1.57	26.0	4	1.8	4.8	1.0	4.3	5.5	.109/20	.47

OTHER LENGTHS AND WINDINGS AVAILABLE UPON REQUEST

- Part numbers listed are for single shaft. To order double shaft add 'D' to the end.