

Features

- ▲ Micro size
- ▲ Low cost
- ▲ Designed for board-level integration
- ▲ Ready-for-use mounting card available
- ▲ Single potentiometer for velocity loop adjustments
- ▲ DIP switch selectable modes
- ▲ Four quadrant regenerative operation
- ▲ Hall sensor commutation

Modes of Operation:

- Current (torque)
- Open Loop (voltage)
- Hall Velocity

Command Source:

- $\pm 10V$ analog input

Feedback Supported

- Halls

Inputs/Outputs

- Current reference output
- Current monitor output
- Velocity monitor output
- Bridge inhibit/enable input
- Fault indication output

Protection

- Over voltage
- Under voltage
- Short circuit (phase-to-phase or phase-to-ground)
- Over current
- Drive over temperature
- Hall sensor feedback error

Power Range

Peak Current	6 A (4.2 A _{RMS})
Continuous Current	3 A (2.1 A _{RMS})
Supply Voltage	16-60 V _{DC}

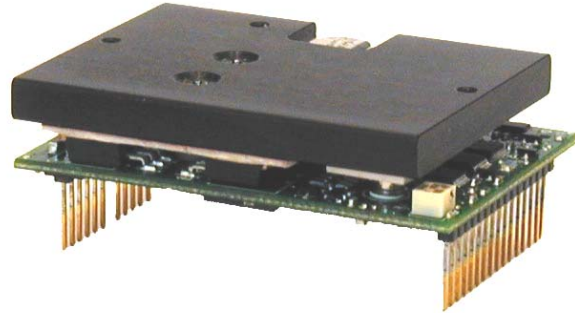

Brushless Series

Description

The ZBH6A6 PWM servo drive is designed to drive brushless DC motors at a high switching frequency. The drive is fully protected against over-voltage, under-voltage, over-current, over-heating, and short-circuits at the output. A single digital output indicates operating status. This drive can interface with any controller that has analog $\pm 10V$ output and may be powered by a single unregulated and isolated DC power supply.

Available Options

- Inverted inhibit/enable logic (-INV)
- Analog positioning (-ANP)

BLOCK DIAGRAM

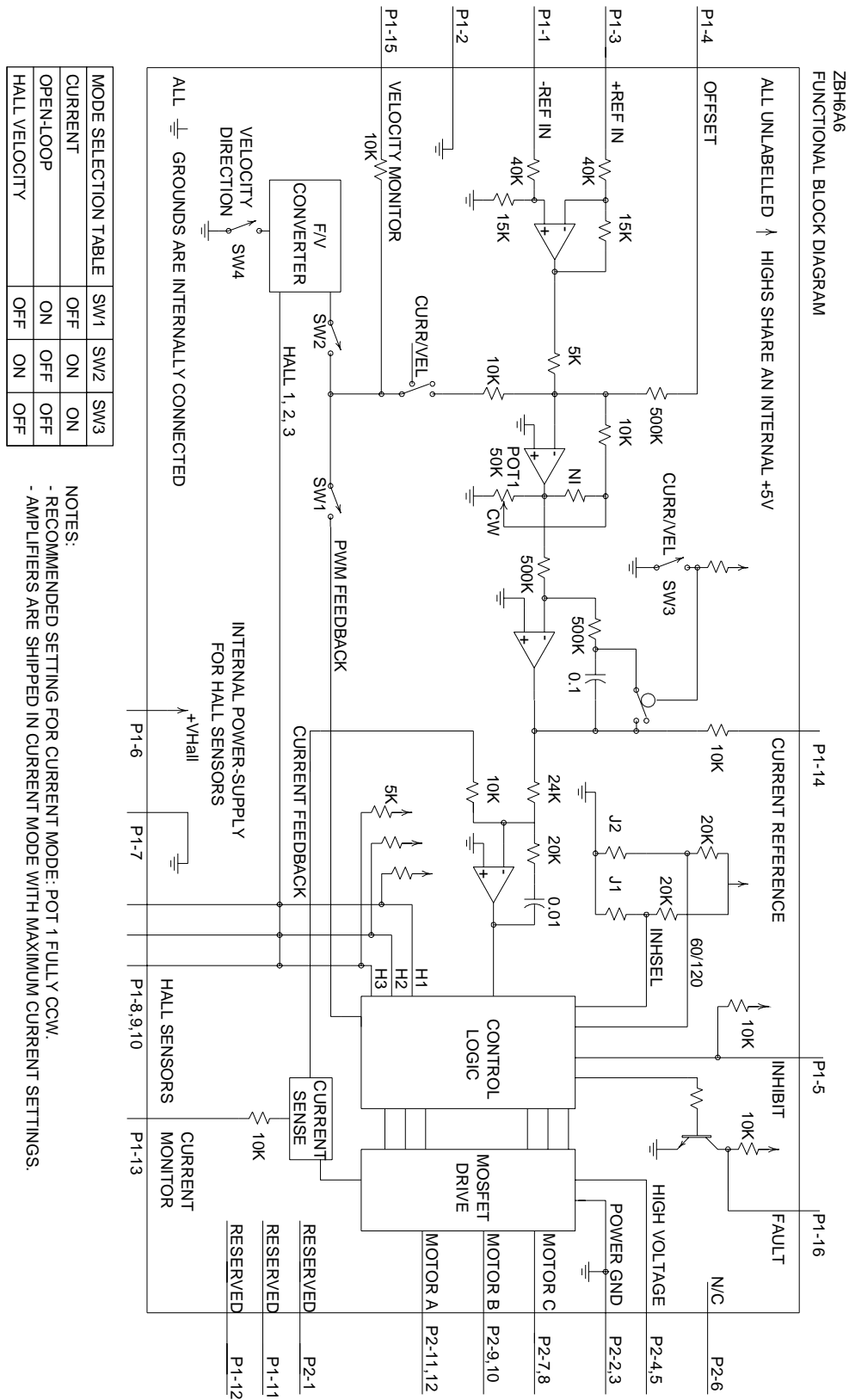

SPECIFICATION SUMMARY

Power Stage Specifications	
DC Supply Voltage	16 - 60 V
Peak Output Current	± 6 A (4.2 A _{RMS})
Maximum Continuous Output Current ¹	± 3 A (2.1 A _{RMS})
Minimum Load Inductance ²	100 µH
Switching Frequency	50 kHz
Heatsink (Base) Temperature Range	0 ° to + 65° C, disables if > 65° C
Power Dissipation at Continuous Current	10 W
Internal Bus Capacitance	33 µF
Over-Voltage Limit	68 V
Control Specifications	
Commutation Method	Trapezoidal
Max Hall Frequency ³	1 kHz
Mechanical Specifications	
Signal Connector: P1	16-pin header, 0.1 in (2.54 mm) pitch
Power Connector: P2	12-pin header, 0.1 in (2.54 mm) pitch
Size (L x W x H)	2.70 x 2.00 x 1.09 in 68.6 x 50.8 x 27.7 mm

Notes

1. Maximum duration of peak current is ~2 seconds.
2. Low inductance motors (such as 'pancake' and 'basket-wound') require external inductors. The Minimum Load Inductance provided assumes the highest allowed bus voltage. Lower inductances are acceptable for lower bus voltages.
3. Measured in electrical cycles per second.

PIN FUNCTIONS

P1 – Signal Connector			
Pin	Name	Description	I/O
1	REF+ IN	Positive terminal of differential analog input.	I
2	GROUND	Reference ground.	GND
3	REF- IN	Negative terminal of differential analog input.	I
4	OFFSET	Connection to external resistance for command offset adjustments.	-
5	INHIBIT IN	Inhibit/enable input.	I
6	+VHALL	+6 VDC (@ 30 mA) source for Hall sensors.	O
7	GROUND	Reference ground.	GND
8	HALL 1	Hall sensor inputs.	I
9	HALL 2		
10	HALL 3		
11	RESERVED	Reserved.	-
12	RESERVED	Reserved.	-
13	CURRENT MONITOR	Output voltage proportional to motor output current. Scaling: 2 A/V.	O
14	CURRENT REFERENCE	Monitors the signal at the input of the internal current amplifier stage. Scaling: 0.8 A/V.	O
15	VELOCITY MONITOR	When used in current or Hall velocity mode, voltage is proportional to the speed of the motor. In open-loop mode, voltage is proportional to the PWM duty cycle. Scaling: 100 Hz/V	O
16	FAULT OUT	Logic output for indication of a drive fault.	O

P2 – Power Connector			
Pin	Name	Description	I/O
1	RESERVED	Reserved.	-
2	GROUND	Reference ground (current rating of 3A per pin).	GND
3			
4	HIGH VOLTAGE	DC power input (current rating of 3A per pin).	I
5			
6	N/C	Not connected. Pin has been removed.	-
7	MOTOR C	Motor phase C connection (current rating of 3A per pin).	O
8			
9	MOTOR B	Motor phase B connection (current rating of 3A per pin).	O
10			
11	MOTOR A	Motor phase A connection (current rating of 3A per pin).	O
12			

SWITCH & POTENTIOMETER FUNCTIONS

Switch	Description	Setting	
		On	Off
SW1	Internal voltage/PWM feedback for open-loop mode.	Feedback active	Feedback inactive
SW2	Hall sensor monitor/feedback.	Monitor/feedback active	Monitor/feedback inactive
SW3	Current mode selector.	Current mode only	Voltage/velocity modes
SW4	Velocity feedback polarity.	Standard	Inverted

Refer to the block diagram at the beginning of this datasheet for a mode selection table of valid switch settings.

Potentiometer	Description	Setting	
		Turning CCW	Fully CW
POT1	Loop gain adjustment for voltage/velocity modes. Turn this pot fully CCW in current mode.	Decrease loop gain	Increase loop gain

The single potentiometer on this drive varies in resistance over 11 turns and has a maximum resistance of 50 k Ω .

CONNECTOR INFORMATION

P1 – I/O Connector

Connector Information	16-pin header, 0.1 in (2.54 mm) pitch
Mating Connector Example	Samtec P/N: BCS-116-L-S-PE

P2 – Power Connector

Connector Information	12-pin header, 0.1 in (2.54 mm) pitch
Mating Connector Example	Samtec P/N: BCS-112-L-S-PE

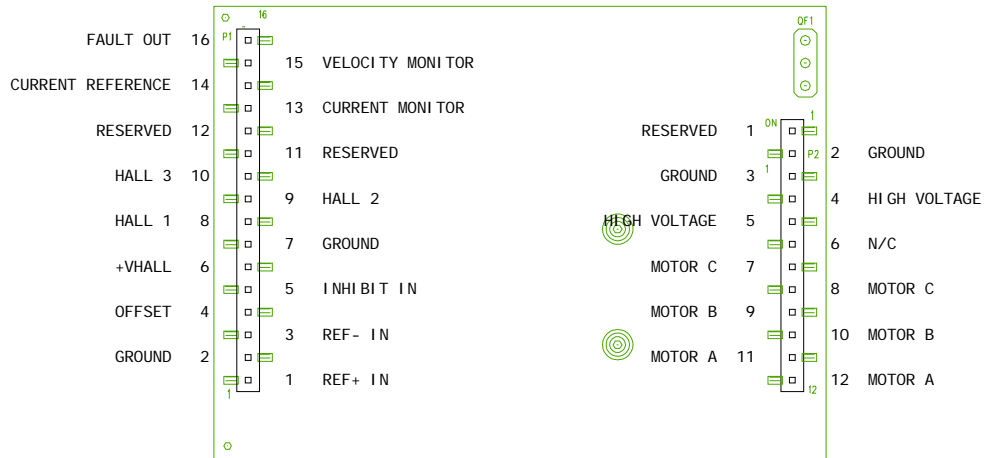

ORDERING INFORMATION

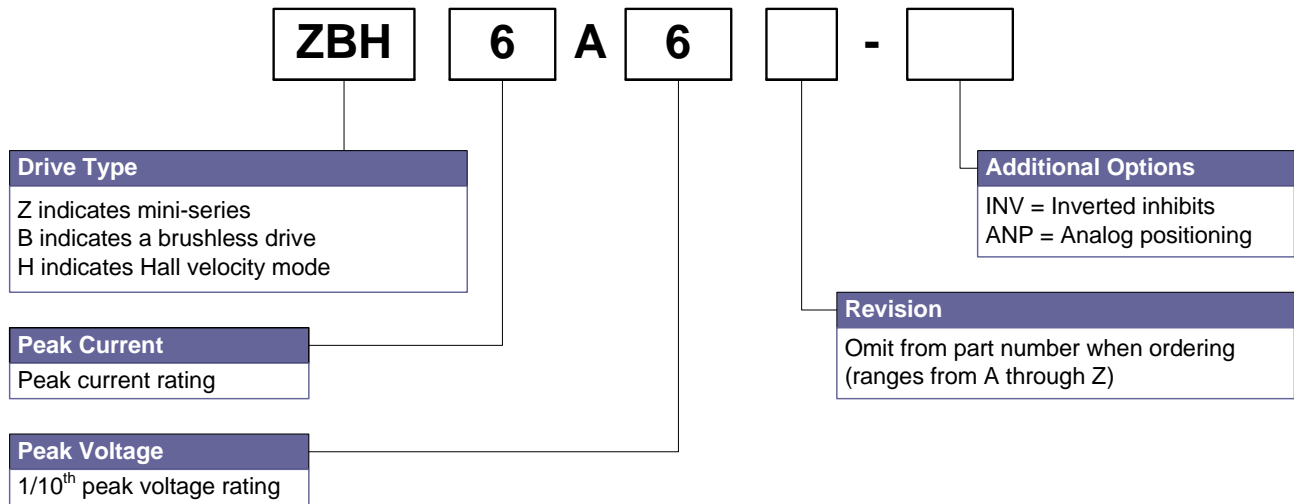

Notes:

Peak Current

Maximum continuous current rating is approximately 1/2 of the peak current rating.

Revision

This letter is not required when placing an order.
Some letters are skipped when assigning revisions.

Additional Options

Options not listed here are for custom drives. Contact an AMC representative for more information.

Alternative Drives
<p><u>DIGITAL</u> ZDCR300EE12A8LDC ZDR300EE12A8LDC</p> <p><u>ANALOG</u> ZBH12A8 ZBE6A6 ZBE12A8</p> <p>Bold: mechanically identical drives.</p>

Available Accessories	Accessory Part Numbers
Mounting Card	MC1XZBHE
Shunt Regulator	SRST50
Filter Card	BFC1010
	BFC10010
Power Supply	PS16L30 / PS16H30
	PS16L36 / PS16H36
	PS16L40 / PS16H40
	PS16L60 / PS16H60
	PS16L80 / PS16H80
	PS2X3H24 / PS2X3W24
	PS2X3H48 / PS2X3W48
	PS300H24 / PS300W24
	PS300H48 / PS300W48