

SERIES ZB12A BRUSHLESS PWM SERVO AMPLIFIERS

Models: ZB6A6, ZB12A8 Micro Series

FEATURES:

- Micro size, low cost, ease of use
- Analog +/-10V input commands
- For brushless motors
- Torque Mode
- Closed current loop
- No pots or switches
- Surface-mount technology
- Four quadrant regenerative operation
- Hall sensor commutation
- Agency approvals: Pending

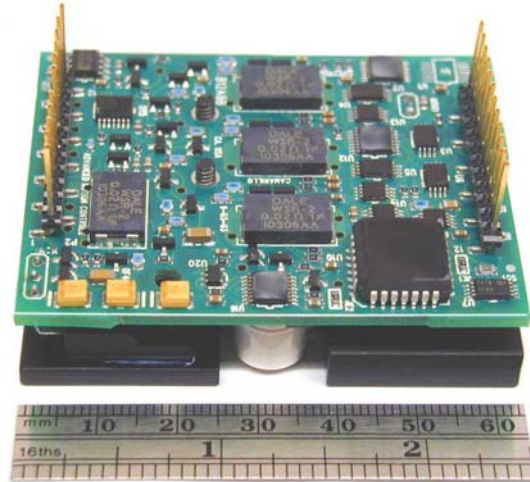

BLOCK DIAGRAM:

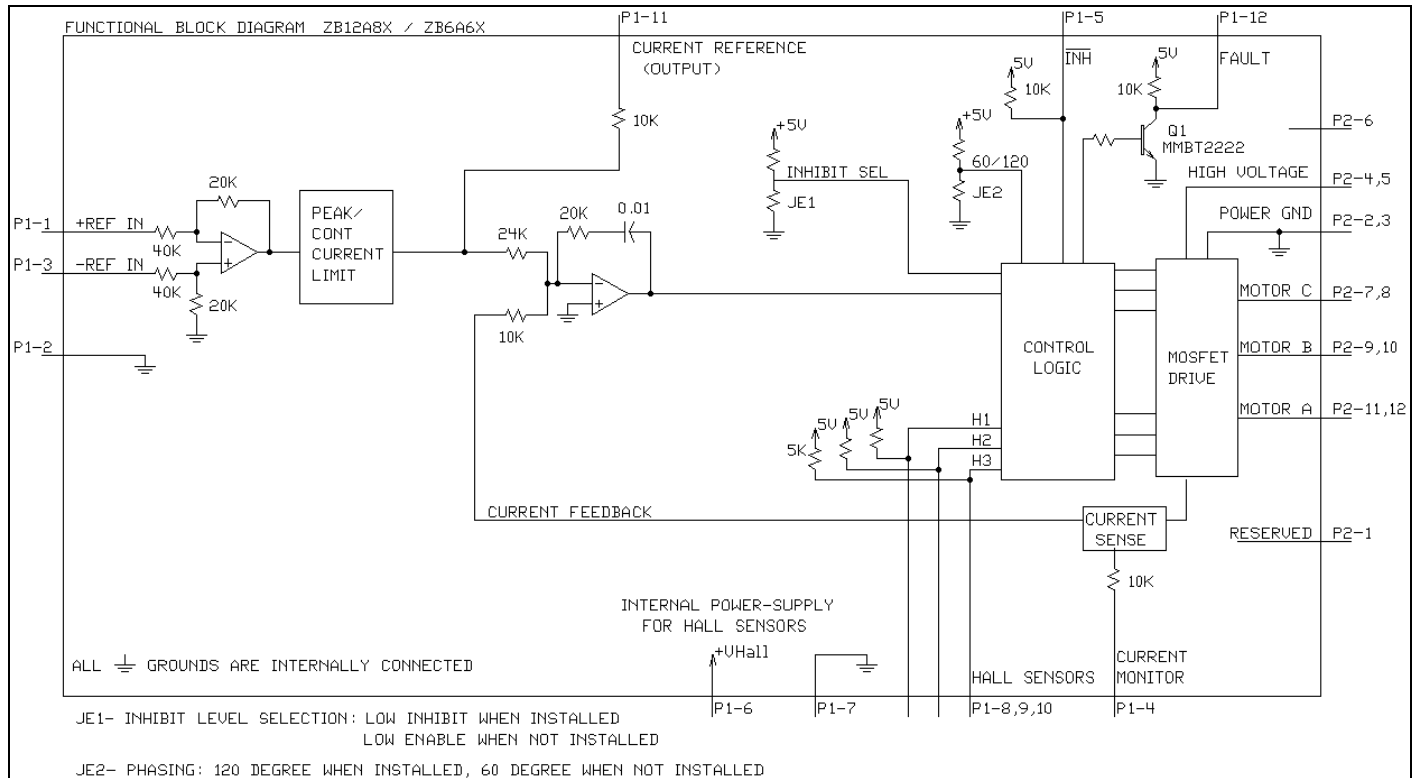

DESCRIPTION: The ZB12A Series PWM servo amplifiers are designed to drive brushless DC motors at a high switching frequency. They are fully protected against over-voltage, over-current, over-heating and short-circuit. A single digital output indicates operating status. All models interface with digital controllers that have analog +/-10V output. These servo amplifiers require only a single unregulated isolated DC power supply.

SPECIFICATIONS:

POWER STAGE SPECIFICATIONS	MODELS	
	ZB6A6	ZB12A8
DC SUPPLY VOLTAGE	16 – 60 VDC	16 – 80 VDC
PEAK CURRENT (2 sec. max., internally limited)	± 6 A	± 12 A
MAX. CONTINUOUS CURRENT (internally limited)	± 3 A	± 6 A
MINIMUM LOAD INDUCTANCE *	100 µH	100 µH
SWITCHING FREQUENCY	50 kHz ± 15%	33 kHz ± 15%
HEATSINK (BASE) TEMPERATURE RANGE **	0° to +75° C, disables if > 75° C	
POWER DISSIPATION AT CONTINUOUS CURRENT	10 W	24 W
OVER-VOLTAGE SHUT-DOWN (self reset)	67 V	88 V
BANDWIDTH (load dependent)	5 kHz	

MECHANICAL SPECIFICATIONS	
MOTOR POWER CONNECTOR	12-pin, 0.1 inch spacing, vertical Molex connector
SIGNAL CONNECTORS	12-pin, 0.1 inch spacing, vertical Molex connector
SIZE (thickness does not include length of pins)	2.5 x 2.0 x .71 inches 63.5 x 50.8 x 18.0 mm
WEIGHT	3.1 oz 87.9 g

* Low inductance motors require external inductors.

** Additional cooling may be necessary when bus voltage exceeds 55VDC. Example: Temperature rise can be limited to less than 15°C at continuous current with 110 CFM airflow across the baseplate under the condition 25°C ambient and 80VDC bus. Much lower temperature rise can be achieved at lower bus voltages.

PIN FUNCTIONS:

CONNECTOR	PIN	NAME	DESCRIPTION / NOTES	I/O
P1	1	+REF IN	Differential analog input, maximum +/-15VDC, 40K input resistance	I
	2	SIGNAL GROUND	Reference ground	GND
	3	-REF IN	Differential analog input, maximum +/-15VDC, 40K input resistance	I
	4	CURRENT MONITOR OUT	Output voltage proportional to motor output current: ZB6A6: 1V = 2A; ZB12A8: 1V = 4A	O
	5	INHIBIT IN	This TTL level input signal turns off all power devices of the "H" bridge when pulled to ground (when JE1 is installed), which is a fault condition. If the JE1 jumper is removed, pulling this pin to ground will enable the outputs.	I
	6	+V HALL OUT	+6VDC @ 30 mA output for Hall sensor power	O
	7	SIGNAL GROUND	Reference ground	GND
	8	HALL 1	Hall sensor inputs; TTL logic levels; internal 5k Ω pull-up to 5V. The standard commutation is for 120-degree phased motors. For 60-degree motors, JE2 must be removed.	I
	9	HALL 2		
	10	HALL 3		
	11	CURRENT REF OUT	Monitors the input signal connected directly to the internal current amplifier. 7.25V = max. peak current.	O
	12	FAULT OUT	TTL level output. Becomes high during output short circuit, over-voltage, over temperature and power-up reset.	O
P2	1	RESERVED	Reserved	
	2	POWER GROUND	Power ground (current rating per pin = 3A)	GND
	3			
	4	HIGH VOLTAGE	DC Power Input (current rating per pin = 3A)	I
	5			
	6	NC	(no connection; pin removed)	
	7	MOTOR C	Motor phase C connection (current rating per pin = 3A)	O
	8			
	9	MOTOR B	Motor phase B connection (current rating per pin = 3A)	O
	10			
	11	MOTOR A	Motor phase A connection (current rating per pin = 3A)	O
	12			

JUMPER SETTINGS:

Pin P1-5 can be used to enable or disable the power output to the motor. The default logic level to disable this amplifier is a LOW signal at P1-5. With the jumper JE1 removed, the amplifier will be disabled until a LOW signal is applied to P1-5.

JE2 is a jumper to select between a 120-degree phased motor and a 60-degree phased motor. The default setting is 120-degree commutation phasing. Removing the JE2 jumper will change the setting to 60-degree.

Please note that JE1 and JE2 are very small SMT jumpers. Only qualified technicians are recommended to perform these modifications. The product warranty will be affected by poor quality modifications.

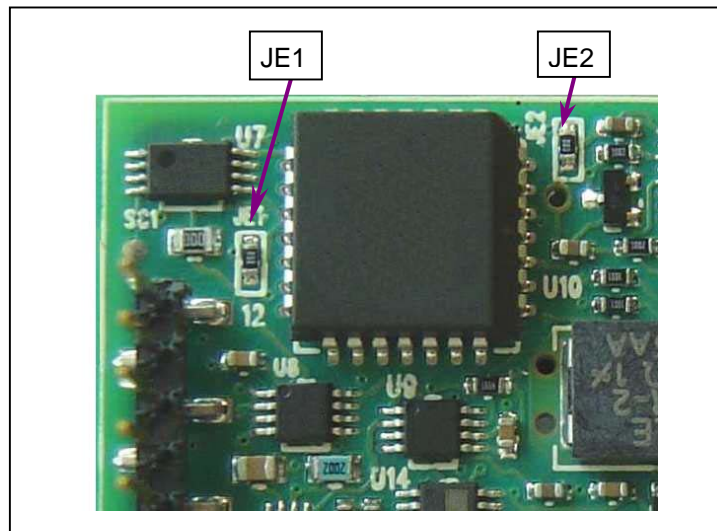

	INSTALLED	NOT INSTALLED
JE1: INHIBIT LEVEL (P1-5)	LOW to Inhibit	LOW to Enable
JE2: COMMUTATION PHASING	120-degree	60-degree

MOUNTING CARDS:

With its vertical pin connections, the ZB12A can be mounted directly to a PC board. However, we also supply the following optional mounting cards for easy interface between components without having to design your own PCB. Please refer to the datasheets for more information.

1. MC2XZQD – Z series amplifiers interface board for up to 2 axes. All connectors are quick-disconnect for easy prototyping. PCB width is 72mm for compatible standard DIN mounting trays.
2. MC4XZGAL – mounts to Galil's DMC-21x3 controller card for up to 4 axes of Z series amplifiers, with D-sub feedback and I/O connectors.
3. MC4XZGALQD – mounts to Galil's DMC-21x3 controller card for up to 4 axes of Z series amplifiers, with quick-disconnect screw terminals for easy prototyping. The mating connector kit is sold separately (KIT4XZGALQD).

ORDERING INFORMATION:

Models: ZB6A6X, ZB12A8X

The X indicates current revision letter.

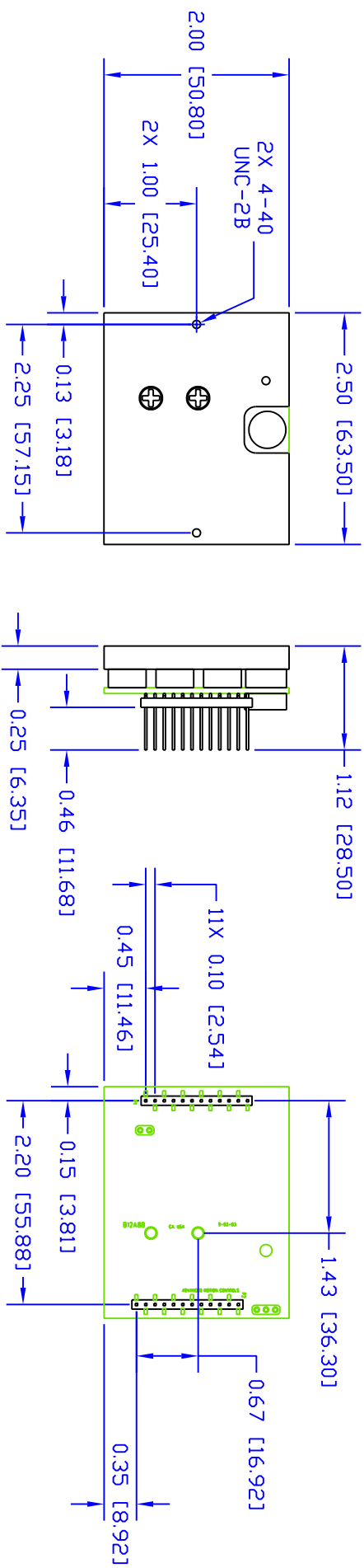

2. OPT. NYLON STANDOFF FOR RETENTION.
 (p/n Amatom 8105-N-0440 or equiv.)

1. DIMENSIONS IN [] ARE IN MM.

NOTES: UNLESS OTHERWISE SPECIFIED.

REV	B	REMOVED DIM 0.16 [3.96]	DATE	02/04/04	BY	PM	ECD
UNLESS OTHERWISE SPECIFIED: DIMENSIONS ARE IN INCHES TOLERANCES .XX ± .010 XXX ± .005 DO NOT SCALE DRAWING							
DRAWN BY:		P. MEAD		DATE:		10/15/03	
CHECK BY:				DATE:			
DESIGN APPROVED:				DATE:			
USED ON							
TITLE				MOUNTING DIMENSIONS, Z SERIES			
ADVANCED MOTION CONTROLS • PWM SERVO AMPLIFIERS • 3805 Calle Tecate, Camarillo, CA 93012				SCALE: FULL			
SIZE		DWG. NO.		REV		B	
B		MDZ		B		SHT. 1 OF	