

S60A SERIES THREE PHASE SINUSOIDAL BRUSHLESS SERVO AMPLIFIERS

Model: S60A8

FEATURES:

- Surface-mount technology
- Small size, low cost, ease of use
- Optical isolation, see block diagram
- Sinusoidal drive and current control
- Four quadrant regenerative operation
- Agency Approvals:



BLOCK DIAGRAM:

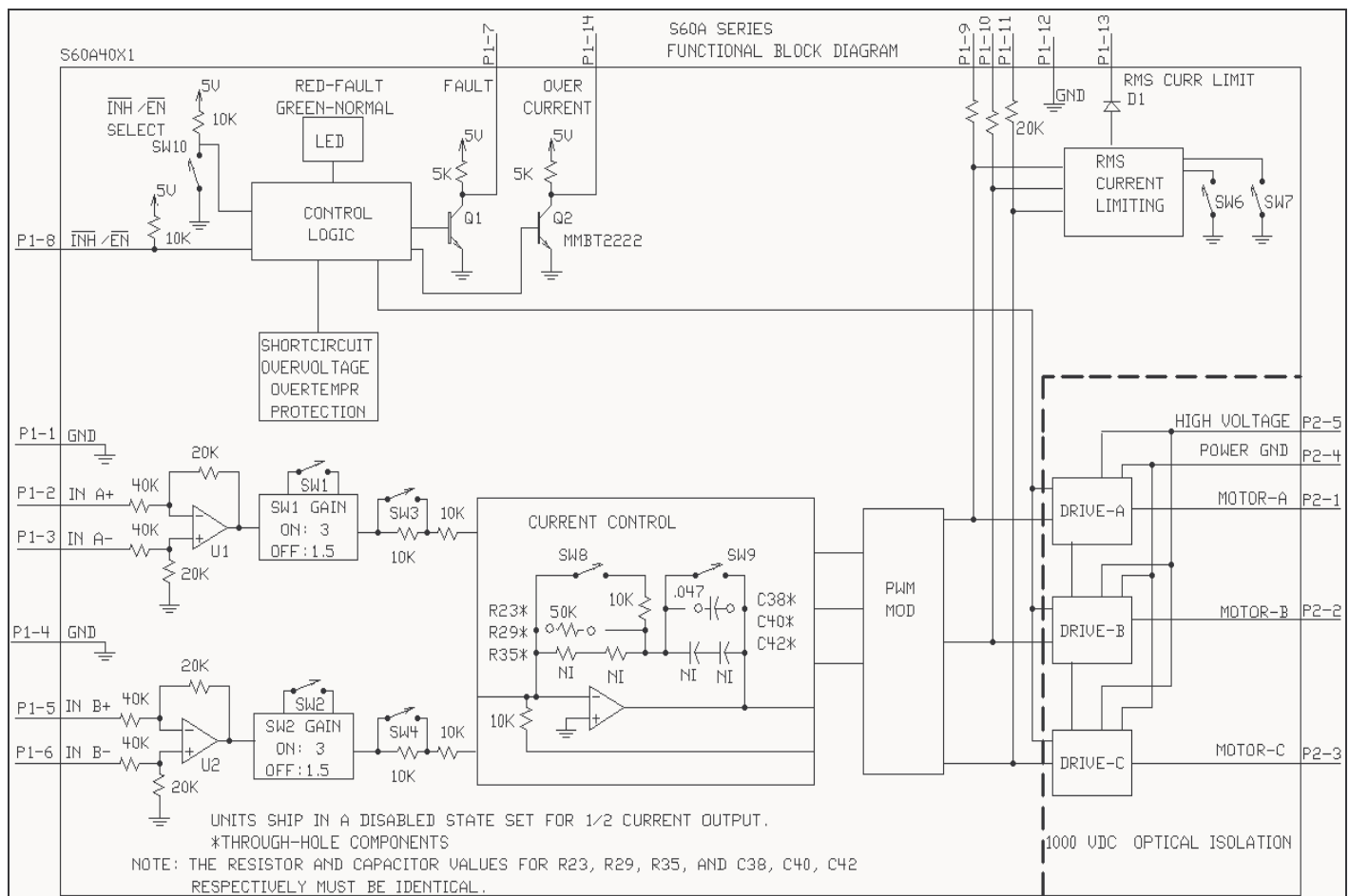

DESCRIPTION: The S60A8 Series PWM servo amplifiers are designed to drive three phase brushless motors with sine wave current at a high switching frequency. They require two sinusoidal command signals with a 120-degree phase shift (external commutation). The phase angle must correspond to the position of the motor rotor, while the signal amplitude controls the motor torque. All models typically interface directly with digital controllers. The amplifiers are fully protected against over-voltage, under-voltage, over-current, over-heating, and short-circuits. The S60A8 series amplifiers require only a single unregulated DC power supply (all logic and control voltages are generated internally). A red/green LED and two digital outputs indicate operating status. All signal inputs and outputs are optically isolated from the power section to eliminate the need for a transformer coupled power supply.

SPECIFICATIONS:

	MODEL
POWER STAGE SPECIFICATIONS	S60A8
DC SUPPLY VOLTAGE	20 – 80 V
PEAK CURRENT (2 sec. max., internally limited)	±60 A (42.4 Arms)
MAXIMUM CONTINUOUS CURRENT (internally limited)	±30 A (21.2 Arms)
MINIMUM LOAD INDUCTANCE *	200 µH
SWITCHING FREQUENCY	15 kHz ± 15 %
HEATSINK (BASE) TEMPERATURE RANGE	0° to +65° C, disables if >65° C
POWER DISSIPATION AT CONTINUOUS CURRENT	600 W
OVER-VOLTAGE SHUT-DOWN (self-reset)	86 V
BANDWIDTH (load dependent)	2.5 kHz

MECHANICAL SPECIFICATIONS	
POWER CONNECTOR: P2	Screw Terminals
SIGNAL CONNECTOR: P1 (optional) **	Optional Molex Connector
SIGNAL CONNECTOR: P3	15 pin low density, female D-Sub
SIZE	9.24 x 6.31 x 3.50 inches 234.7 x 160.2 x 88.9 mm
WEIGHT	5.64 lbs. 2.56 kg.

* Low inductance motors require external inductors.

** Optional Molex connector replaces standard D-sub connector.

PIN FUNCTIONS:

CONNECTOR	PIN	NAME	DESCRIPTION / NOTES	I/O
P1/P3	1	SIGNAL GND	Signal ground	SGND
	2	+REF-IN-A	Differential reference input, maximum ± 15 V, 40K input resistance	I
	3	-REF-IN-A		
	4	SIGNAL GND	Signal ground	SGND
	5	+REF-IN-B	Differential reference input, maximum ± 15 V, 40K input resistance	I
	6	-REF-IN-B		
	7	FAULT OUT	This transistor output becomes high during short circuit, over-voltage, under voltage, and power-on reset. A red LED also indicates a fault condition.	O
	8	INHIBIT / ENABLE	This TTL level input signal turns off all power devices of the "H" bridge when pulled to ground with SW10=ON. If SW10 = OFF pulling this pin to ground will enable the amplifier. This inhibit will cause a fault condition and a red LED.	I
	9	CURRENT MONITOR A	Phase current monitor; 7.25 V = maximum peak current setting.	O
	10	CURRENT MONITOR B		
	11	CURRENT MONITOR C		
	12	SIGNAL GROUND	Signal ground	SGND
	13	RMS CURRENT LIMIT	The RMS current limit can be controlled by an external voltage; 5 V = maximum RMS current limit. This is referenced to P1-1. No input to this pin is necessary to obtain maximum current.	I
	14	OVER-CURRENT	This transistor output becomes high if RMS current (in any phase) exceeds RMS current limit.	O
	15	NC	Reserved	
	16	NC	Reserved (Not available on P3)	
P2	1	MOTOR A	Motor phase A connection	O
	2	MOTOR B	Motor phase B connection	O
	3	MOTOR C	Motor phase C connection	O
	4	POWER GND	Power ground	PGND
	5	HIGH VOLTAGE	DC power input	I

SWITCH FUNCTIONS:

SWITCH	FUNCTION DESCRIPTION	SETTING	
		ON	OFF
1	Input Range Selection*	Input range ± 5 V ± 5 V = Max. current when SW1, 2 = ON	Input range ± 10 V ± 10 V = Max. current when SW1, 2 = OFF
2			
3	Peak Current Limit**	The peak current limit equals 100% of the maximum peak current when SW3 and SW4 are ON.	The peak current limit equals 50% of the maximum peak current when SW3 and SW4 are OFF.
4			
5	Reserved		
6	RMS Current Limit	See Table 1 below.	
7			
8	Current Loop Gain***	Decrease	Increase
9	Current Loop Integrator***	Recommended setting is OFF.	
10	INHIBIT/ENABLE SELECT	P1-8: INHIBIT With SW10=ON, pull P1-8 to ground to inhibit the amplifier.	P1-8: ENABLE With SW10=OFF, pull P1-8 to ground to enable the amplifier.

* Switches 1 and 2 must be set the same.

** Switches 3 and 4 must be set the same.

*** See item "6.3 Current Loop Adjustments" in section G for more information.

Units are shipped set for $\frac{1}{2}$ current output via SW3 and SW4=off and in the disabled state via SW10=off.

TABLE 1:

SW6	SW7	PERCENTAGE OF MAXIMUM CONTINUOUS CURRENT
ON	ON	100%
OFF	ON	100%
ON	OFF	50%
OFF	OFF	25%

CURRENT LIMIT:

Current limiting for each motor winding is independent. The peak current is maintained for two seconds. If the RMS value of the winding current exceeds the RMS current limit the amplifier shuts off. The shut off condition is indicated by a high OVER CURRENT signal, a high FAULT signal, and a blinking red LED. The amplifier will re-enable when the RMS current returns to values within the RMS current limit range.

INPUT SIGNAL ISOLATION: All pins on P1/P3 are optically isolated (1000 V) from P2.

ORDERING INFORMATION:

Model: S60A8X

X indicates the current revision letter.

TYPICAL SYSTEM WIRING: See Installation Notes on AMC Website for further details.

MOUNTING DIMENSIONS:

