

## S16A SERIES THREE PHASE SINUSOIDAL BRUSHLESS SERVO AMPLIFIERS

### Model: S16A8

**FEATURES:**

- Surface-mount technology
- Small size, low cost, ease of use
- Sinusoidal drive and current control
- Four quadrant regenerative operation
- Agency approvals:

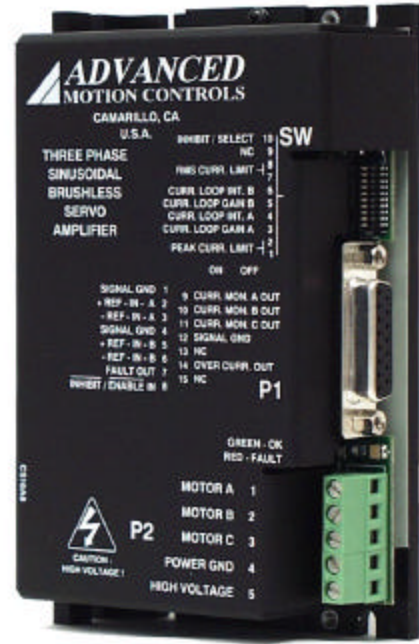

**BLOCK DIAGRAM:**

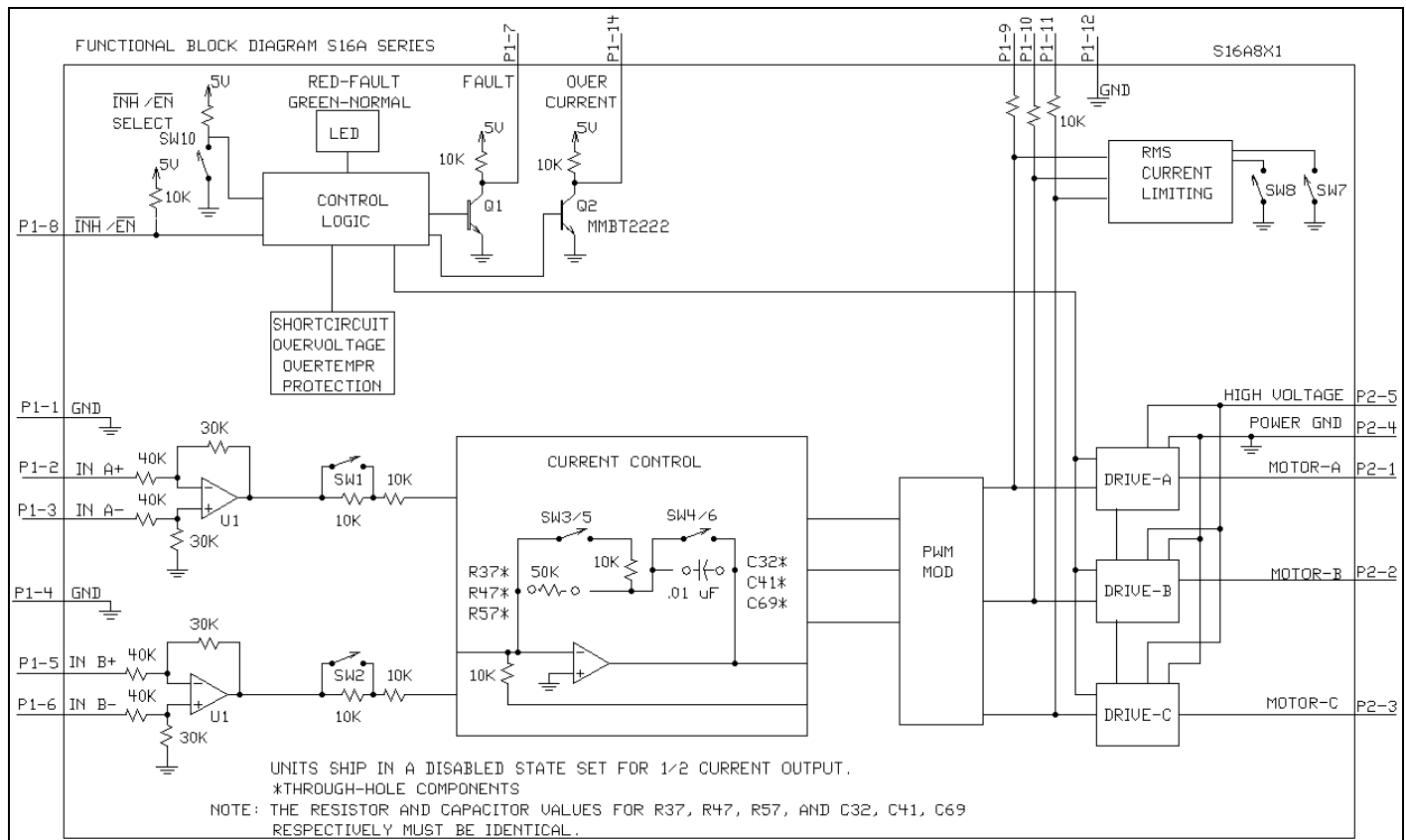

**DESCRIPTION:** S16A Series PWM servo amplifiers are designed to drive three phase brushless motors with sine wave current at a high switching frequency. They require two sinusoidal command signals with a 120-degree phase shift (external commutation). The phase angle must correspond to the position of the motor rotor, while the signal amplitude controls the motor torque. All models typically interface directly with digital controllers. The amplifiers are fully protected against over-voltage, over-current, over-heating, and short-circuits. The S16A series amplifiers require only a single unregulated DC power supply (all logic and control voltages are generated internally). A red/green LED and two digital outputs indicate operating status.

	<b>MODEL</b>
<b>POWER STAGE SPECIFICATIONS</b>	<b>S16A8</b>
DC SUPPLY VOLTAGE	20-80 V
PEAK CURRENT (2 sec. max., internally limited)	±16 A (11.3 Arms)
MAXIMUM CONTINUOUS CURRENT (internally limited)	± 8 A (5.7 Arms)
MINIMUM LOAD INDUCTANCE*	200 µH
SWITCHING FREQUENCY	33 kHz nominal (+/- 15%)
HEATSINK (BASE) TEMPERATURE RANGE	0° to +65° C, disables if >65° C
POWER DISSIPATION AT CONTINUOUS CURRENT	32 W
OVER-VOLTAGE SHUT-DOWN (self-reset)	86 V
BANDWIDTH (load dependent)	2.5 kHz (typical)

<b>MECHANICAL SPECIFICATIONS</b>	
POWER CONNECTOR: P2	Screw Terminals
SIGNAL CONNECTOR: P1	15 pin D-Sub
SIZE	5.09 x 3.06 x 1.52 inches 129.3 x 77.7 x 38.6 mm
WEIGHT	10 oz. 0.28 Kg.

\* Low inductance motors require external inductors.

## PIN FUNCTIONS:

CONNECTOR	PIN	NAME	DESCRIPTION / NOTES	I/O
P1	1	SIGNAL GND	Signal ground	GND
	2	+REF-IN-A	Differential reference input, maximum $\pm 10$ V, 40K input resistance	I
	3	-REF-IN-A		
	4	SIGNAL GND	Signal ground	GND
	5	+REF-IN-B	Differential reference input, maximum $\pm 10$ V, 40K input resistance	I
	6	-REF-IN-B		
	7	FAULT OUT	This transistor output becomes high during short circuit, over-voltage, and power-on reset. A red LED also indicates a fault condition.	O
	8	INHIBIT / ENABLE	This TTL level input signal turns off all power devices of the "H" bridge when pulled to ground with SW10=OFF. If SW10 = ON pulling this pin to ground will enable the amplifier. This inhibit will cause a fault condition and a red LED.	I
	9	CURRENT MONITOR A	Phase current monitor; 1V = 2.2A	O
	10	CURRENT MONITOR B		
	11	CURRENT MONITOR C		
	12	SIGNAL GROUND	Signal ground	GND
	13	NC	Reserved	
	14	OVER-CURRENT	This transistor output becomes high if RMS current (in any phase) exceeds RMS current limit.	O
	15	NC	Reserved	
P2	1	MOTOR A	Motor phase A connection	O
	2	MOTOR B	Motor phase B connection	O
	3	MOTOR C	Motor phase C connection	O
	4	POWER GND	Power ground	GND
	5	HIGH VOLTAGE	DC power input	I

**SWITCH FUNCTIONS:**

SWITCH	FUNCTION DESCRIPTION	SETTING	
		ON	OFF
1	Peak Current Limit*	The peak current limit equals 100% of the maximum peak current when SW1 and SW2 are ON.	The peak current limit equals 50% of the maximum peak current when SW1 and SW2 are OFF.
2			
3	Current Loop Gain**	Decrease	Increase
4	Current Loop Integrator***	Recommended setting is OFF.	
5	Current Loop Gain**	Decrease	Increase
6	Current Loop Integrator***	Recommended setting is OFF.	
7	RMS Current Limit	See Table 1 below.	
8			
9	Reserved		
10	INHIBIT/ENABLE SELECT	P1-8 : ENABLE With SW10=ON, pull P1-8 to ground to enable the amplifier.	P1-8 : INHIBIT With SW10=OFF, pull P1-8 to ground to inhibit the amplifier.

\* Switches 1 and 2 must be set the same.

\*\* Switches 3 and 5 must be set the same – See “6.3 Current Loop Adjustments” in section G for more information.

\*\*\* Switches 4 and 6 must be set the same – See “6.3 Current Loop Adjustments” in section G for more information.

Units are shipped set for ½ current output via SW1 and SW2 and in the disabled state via SW10=on.

**TABLE 1**

SW7	SW8	PERCENTAGE OF MAXIMUM CONTINUOUS CURRENT
ON	ON	100%
ON	OFF	100%
OFF	ON	50%
OFF	OFF	25%

**CURRENT LIMIT**

Current limiting for each motor winding is independent. The peak current is maintained for two seconds. If the RMS value of the winding current exceeds the RMS current limit the amplifier shuts off. The shut off condition is indicated by high OVER CURRENT, high FAULT signal, and blinking red LED. The amplifier will re-enable when the RMS current returns to values within the RMS current limit range.

**ORDERING INFORMATION**

Model: S16A8X

X indicates the current revision letter.

**TYPICAL SYSTEM WIRING:** See section "G".

**MOUNTING DIMENSIONS:** See page F-8.



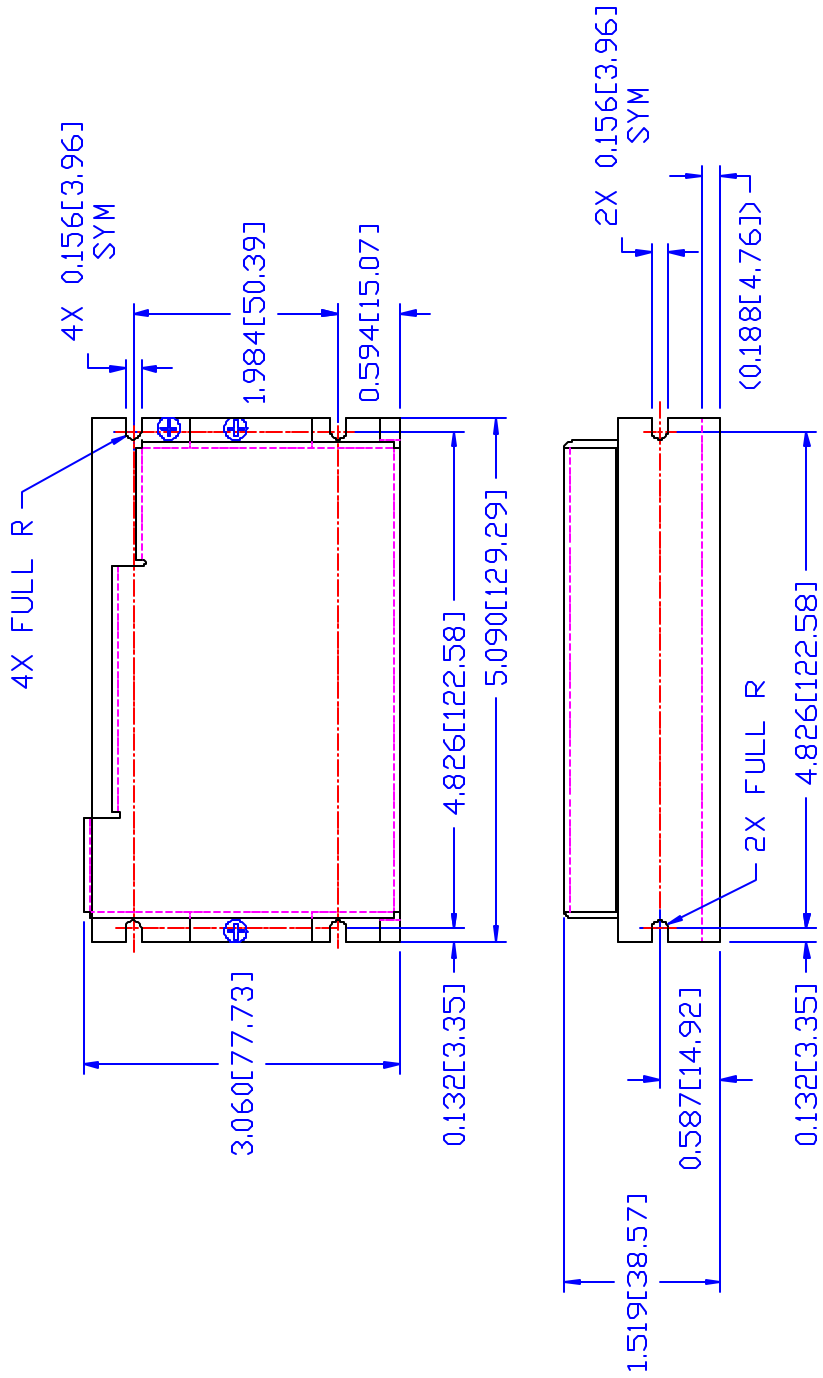

BACKSIDE VIEW

A		CHANGE ADDRESS ON TITLE BLOCK	09/18/01	RB
REV		DESCRIPTION	DATE	BY
UNLESS OTHERWISE SPECIFIED DIMENSIONS ARE IN INCHES TOLERANCES .XX ± .010 .XXX ± .005 DO NOT SCALE DRAWING				
DRAWN BY:		DATE:		
R. BAUTISTA		01/04/99		
CHECK BY:		DATE:		
DESIGN APPROVED:		DATE:		
S16A SERIES				
USED ON				
NOTE: DIMENSIONS ON [		J ARE IN MM.		
		TITLE		
		MOUNTING DIMENSIONS, S16A8		
		SIZE DWG. NO.	REV	
		B	A	
		MDS16A8		
		SCALE: FULL	SHT. 1 OF 1	
		ADVANCED MOTION CONTROLS • PWM SERVO AMPLIFIERS • 3805 Calle Tecate, Cananillo, CA 93012		