

## PS300W SERIES POWER SUPPLIES

### FEATURES:

- Multiple primary windings: either 120 VAC or 240 VAC, 50/60 Hz operation
- 24 VDC secondary output winding taps
- Low cost
- Agency approvals:

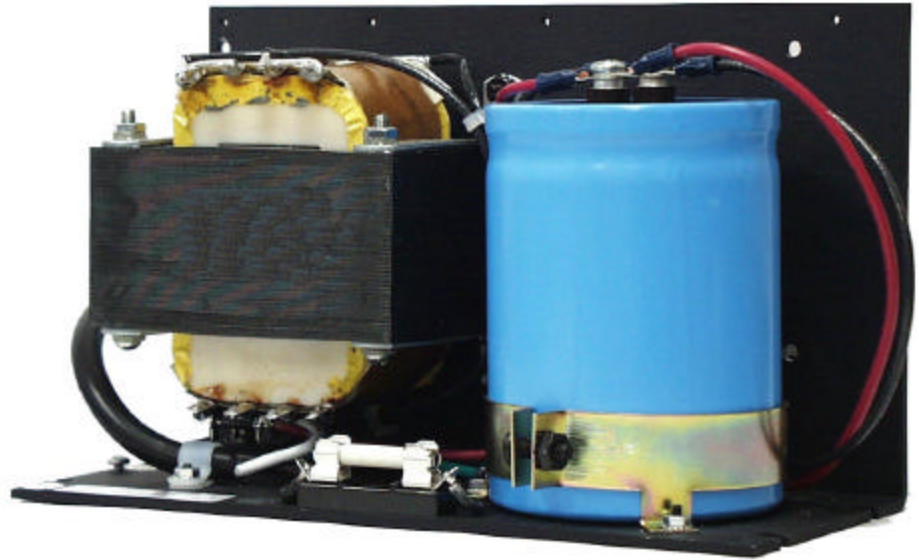

### BLOCK DIAGRAM:

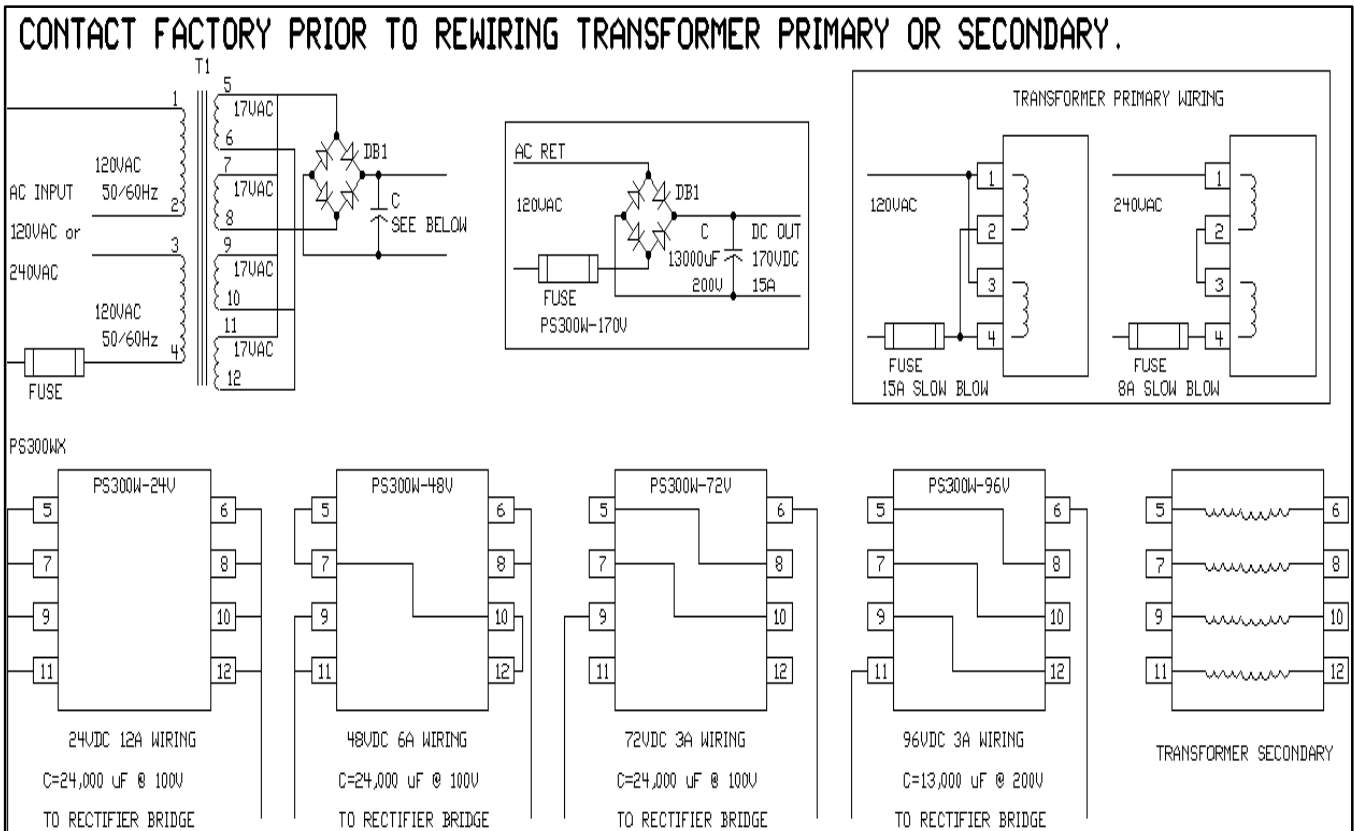

**DESCRIPTION:** The PS300W Series unregulated power supplies have been designed to complement *ADVANCED MOTION CONTROLS'* servo amplifiers and to provide the user with a complete solution to single and multi-axes DC drive applications. These unregulated DC power sources are an excellent solution for most applications as *ADVANCED MOTION CONTROLS'* servo amplifiers compensate for power supply output variations and AC ripple components. PS300W Series power supplies are designed to provide the best cost-per-watt value. They have multiple primary windings for 120VAC and 240VAC, 50/60 Hz operation. These power supplies feature four identical secondary windings that can be connected in series or in parallel for different output voltages and currents.

<b>MECHANICAL SPECIFICATIONS</b>		<b>MODEL</b>
		<b>PS300W</b>
AC INPUT CONNECTOR *		AC cord supplied
DC OUTPUT CONNECTOR		Flying Leads
SIZE		8.60 x 4.05 x 5.63* inches 218.4 x 102.9 x 142.9* mm
WEIGHT		10 lb. 4.53 Kg.

\*Power cord not available with 240 VAC input.

**ORDERING INFORMATION:**

<b>AMC PART NUMBER</b>			
<b>Input Voltage (240VAC)</b>	<b>Input voltage (120VAC)</b>	<b>Output Voltage (VDC)</b>	<b>Nominal Output Current (Amps)</b>
PS300H24	PS300W24	24	12
PS300H48	PS300W48	48	6
PS300H72	PS300W72	72	3
PS300H96	PS300W96	96	3
-	PS300W170	170	15

\*Worst case height dimension. Height varies based on output voltage. See mounting dimensions for additional details.

**MOUNTING DIMENSIONS:** See page F-22.

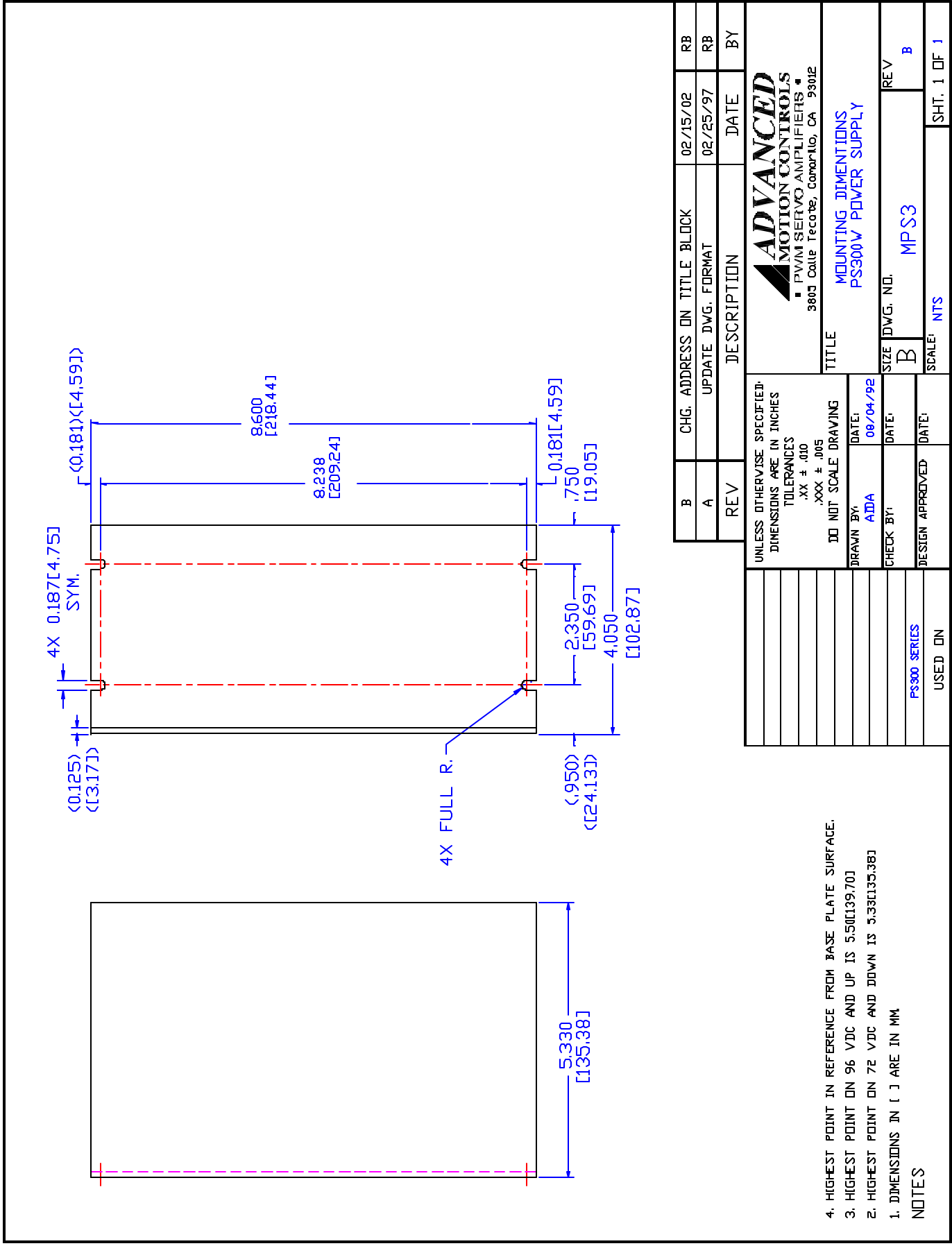

B	CHG. ADDRESS ON TITLE BLOCK	02/15/02	RB
A	UPDATE DWG. FORMAT	02/25/97	RB
REV	DESCRIPTION	DATE	BY

**ADVANCED**  
**MOTION CONTROLS**  
 PVM SERVO AMPLIFIERS  
 3803 Calle Tecote, Compton, CA 93012

TITLE  
**MOUNTING DIMENSIONS**  
**PS300V POWER SUPPLY**

SIZE DWG. NO. REV  
 B MPS3 B  
 SCALE: NTS SHT. 1 OF 1

UNLESS OTHERWISE SPECIFIED, DIMENSIONS ARE IN INCHES	
TOLERANCES	
.XX ± .010	
.XXX ± .005	
DO NOT SCALE DRAWING	
DRAWN BY:	DATE:
ADA	08/04/92
CHECK BY:	DATE:
DESIGN APPROVED:	DATE:
PS-300 SERIES	
USED ON	