

Description

The DZCANTE-012L080 digital servo drive is designed to drive brushed and brushless servomotors from a compact form factor ideal for embedded applications. This fully digital drive operates in torque, velocity, or position mode and employs Space Vector Modulation (SVM), which results in higher bus voltage utilization and reduced heat dissipation compared to traditional PWM. The command source can be generated internally or can be supplied externally. In addition to motor control, this drive features dedicated and programmable digital and analog inputs and outputs to enhance interfacing with external controllers and devices.

The DZCANTE-012L080 features a single RS232 interface used for drive configuration and setup. Drive commissioning is accomplished using DriveWare300 available at www.a-m-c.com. The CANopen interface can be used for online operation in networked applications.

All drive and motor parameters are stored in non-volatile memory.

Power Range

Peak Current	12 A (8.5 A _{RMS})
Continuous Current	6 A (4.2 A _{RMS})
Supply Voltage	20 - 80 VDC

**Features**

- ▲ Four quadrant regenerative operation
- ▲ Space vector modulation (SVM) technology
- ▲ Fully digital state-of-the-art design
- ▲ Programmable gain settings
- ▲ Fully configurable current, voltage, velocity and position limits
- ▲ PIDF velocity loop
- ▲ PID + FF position loop
- ▲ Compact size, high power density

MODES OF OPERATION

- Current
- Position
- Velocity

COMMAND SOURCE

- ±10 V Analog
- 5V Step & Direction
- Communication Interface

FEEDBACK SUPPORTED

- Halls
- Incremental Encoder
- ±10 V Analog
- Auxiliary Incremental Encoder

INPUTS/OUTPUTS

- 2 High Speed Captures
- 1 Programmable Analog Input
- 0 Programmable Analog Outputs
- 2 Programmable Digital Inputs (Differential)
- 3 Programmable Digital Inputs (Single-Ended)
- 3 Programmable Digital Outputs



COMPLIANCES & AGENCY APPROVALS

- RoHS
- UL/cUL Pending
- CE Pending

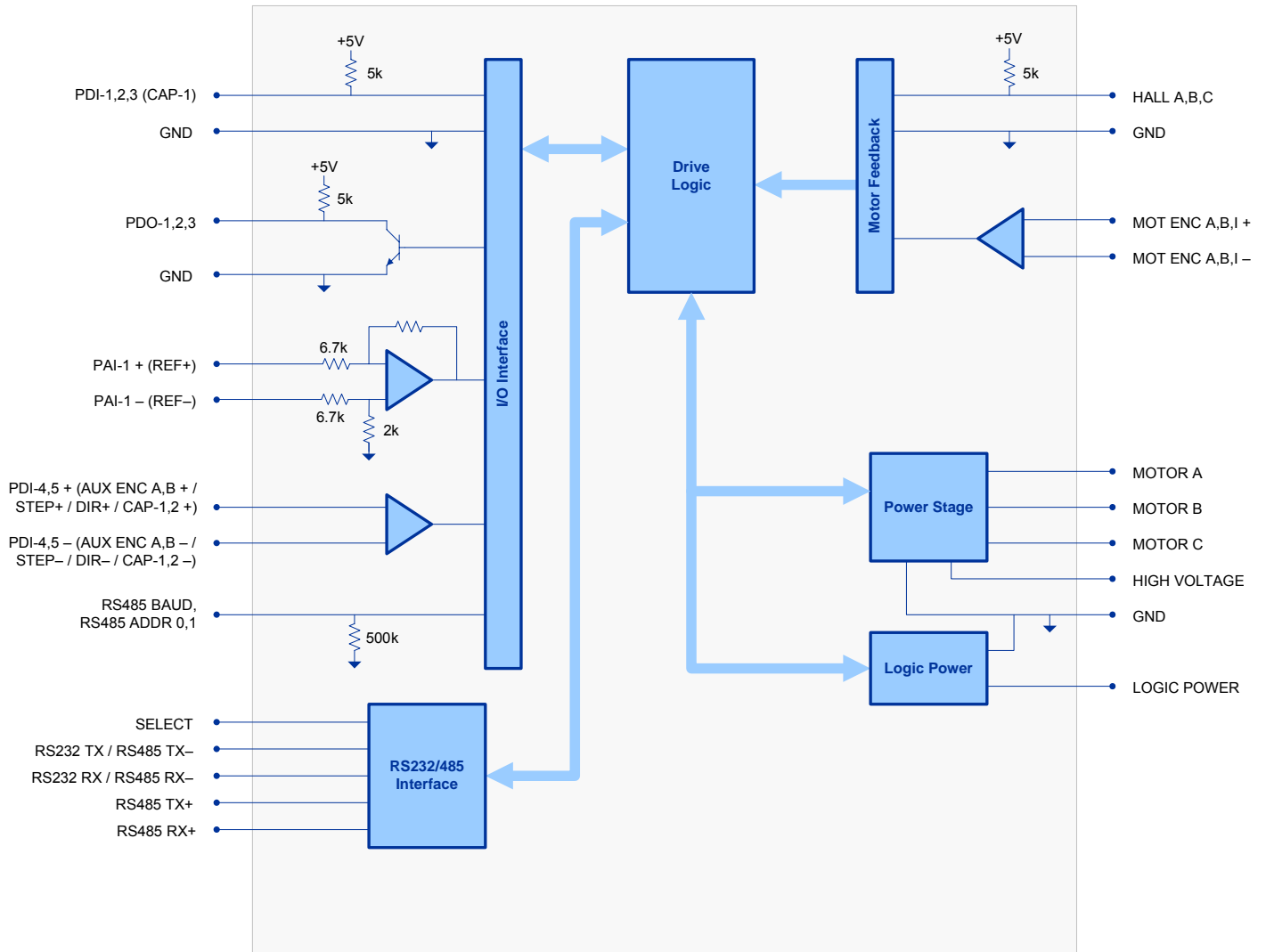
BLOCK DIAGRAM



Approvals and Compliances

	<p>US and Canadian safety compliance with UL 508c, the industrial standard for power conversion electronics. UL registered under file number E140173. Note that machine components compliant with UL are considered UL registered as opposed to UL listed as would be the case for commercial products.</p>
	<p>Compliant with European CE for both the Class A EMC Directive 89/336/EEC on Electromagnetic Compatibility (specifically EN 61000-6-4:2001, EN 61000-6-2:2001, EN 61000-3-2:2000, and EN 61000-3-3:1995/A1:2001) and LVD requirements of directive 73/23/EEC (specifically EN 60204-1), a low voltage directive to protect users from electrical shock.</p>
	<p>RoHS (Reduction of Hazardous Substances) is intended to prevent hazardous substances such as lead from being manufactured in electrical and electronic equipment.</p>

SPECIFICATIONS

Power Stage Specifications		
Description	Units	Value
DC Supply Voltage	VDC	20 - 80
Over Voltage Limit	VDC	86
Under Voltage Limit	VDC	17
Peak Output Current	A	12
Maximum Continuous Output Current	A	6
Maximum Continuous Output Power	W	480
Maximum Power Dissipation at Continuous Current	W	24
Internal Bus Capacitance	µF	33
Minimum Load Inductance (Line-To-Line) ¹	µH	250
Switching Frequency	kHz	20
Control Specifications		
Description	Units	Value
Communication Interfaces	-	CANopen (ISO 11898-2), RS-232
Command Sources	-	±10 V Analog, 5V Step & Direction, Communication Interface
Feedback Supported	-	±10 V Analog, Auxiliary Incremental Encoder, Halls, Incremental Encoder
Commutation Methods	-	Sinusoidal, Trapezoidal
Modes of Operation	-	Current, Position, Velocity
Motors Supported	-	Brushed, Brushless, Induction, Voice Coil
Hardware Protection	-	40+ Configurable Functions, Over Current, Over Temperature (Drive & Motor), Over Voltage, Short Circuit (Phase-Phase & Phase-Ground), Under Voltage
Programmable Digital Inputs/Outputs (PDIs/PDOs)	-	5/3
Programmable Analog Inputs/Outputs (PAIs/PAOs)	-	1/0
Current Loop Sample Time	µs	50
Velocity Loop Sample Time	µs	100
Position Loop Sample Time	µs	100
Max Encoder Line Frequency ²	MHz	4
Mechanical Specifications		
Description	Units	Value
Size (H x W x L)	mm (in)	18.5 x 50.8 x 63.5 (0.7 x 2 x 2.5)
Weight	g (oz)	95.2 (3.4)
Heatsink (Base) Temperature Range ³	°C (°F)	0 - 65 (32 - 149)
Storage Temperature Range	°C (°F)	-40 - 85 (-40 - 185)
Cooling System	-	Natural Convection
Form Factor	-	PCB Mounted
P1 Connector	-	30-pin, 2.54 mm spaced, dual-row header
P2 Connector	-	12-pin, 2.54 mm spaced header

Notes

1. Low inductance motors, such as 'pancake' and 'basket-wound', require external inductors. The Minimum Load Inductance provided assumes the highest allowed bus voltage. Lower inductances are acceptable for lower bus voltages.
2. Pre-quadrature frequency.
3. Additional cooling and/or heatsink may be required to achieve rated performance.

PIN FUNCTIONS

P1 - Signal Connector			
Pin	Name	Description / Notes	I/O
1	CAN ADDR 0	CAN Bus Address Selector	I
2	CAN ADDR 1		I
3	PAI-1 - (REF-)	Differential Programmable Analog Input or Reference Signal Input	I
4	PAI-1 + (REF+)		I
5	GND	Ground	GND
6	CAN BAUD	CAN bus bit rate selector.	I
7	PDO-1	Programmable Digital Output	O
8	PDO-2	Programmable Digital Output	O
9	PDO-3	Programmable Digital Output	O
10	PDI-1	Programmable Digital Input	I
11	PDI-2	Programmable Digital Input	I
12	PDI-3 (CAP-1)	Programmable Digital Input or High Speed Capture	I
13	RS232 RX	Receive Line (RS-232)	I
14	CAN RX	CAN Receive Line (Requires External Transceiver)	I
15	RS232 TX	Transmit Line (RS-232)	O
16	CAN TX	CAN Transmit Line (Requires External Transceiver)	O
17	PDI-4 + (AUX ENC A+ / CAP-2)	Programmable Digital Input or Auxiliary Encoder or High Speed Capture	I
18	PDI-4 - (AUX ENC A-)	Programmable Digital Input or Auxiliary Encoder (For Differential Signals Only)	I
19	PDI-5 + (AUX ENC B+ / CAP-3)	Programmable Digital Input or Auxiliary Encoder or High Speed Capture	I
20	PDI-5 - (AUX ENC B-)	Programmable Digital Input or Auxiliary Encoder (For Differential Signals Only)	I
21	GND	Ground	GND
22	HALL A	Single-ended Commutation Sensor Input (For Differential Inputs See MC1XZDCR Datasheet For Recommended Signal Conditioning)	I
23	HALL B		I
24	HALL C		I
25	MOT ENC I+	Differential Encoder Index Input (See MC1XZDCR Datasheet For Recommended Signal Conditioning)	I
26	MOT ENC I-		I
27	MOT ENC A+	Differential Encoder A Channel Input (See MC1XZDCR Datasheet For Recommended Signal Conditioning)	I
28	MOT ENC A-		I
29	MOT ENC B+	Differential Encoder B Channel Input (See MC1XZDCR Datasheet For Recommended Signal Conditioning)	I
30	MOT ENC B-		I

P2 - Power Connector			
Pin	Name	Description / Notes	I/O
1	LOGIC PWR	Logic Supply Input	I
2	GND	Ground	GND
3	GND	Ground	GND
4	HIGH VOLTAGE	DC Power Input	I
5	HIGH VOLTAGE	DC Power Input	I
6	RESERVED	Reserved	-
7	MOTOR C	Motor Phase C	O
8	MOTOR C	Motor Phase C	O
9	MOTOR B	Motor Phase B	O
10	MOTOR B	Motor Phase B	O
11	MOTOR A	Motor Phase A	O
12	MOTOR A	Motor Phase A	O

Pin Details

CAN ADDR 0 (P1-1)

This pin, CAN ADDR 0, as well as CAN ADDR 1, are used for CAN bus addressing. To set the CAN node address of a drive, use the formula

$$CANAddress = \frac{7 * Addr0}{3} + 8 * \frac{7 * Addr1}{3}$$

where *CANAddress* is the desired node address and *Addr0* and *Addr1* represent the voltage that should be applied to pins CAN ADDR 0 and CAN ADDR 1, respectively. The values for *Addr0* and *Addr1* are always integer multiples of 3/7 V within the range 0-3 V. Examples of the voltages required to set certain node addresses are given in the table below. Note that setting a CAN address of 0 will utilize the address stored in non-volatile memory.

CAN ADDR 0 Value (V)	CAN ADDR 1 Value (V)	CAN ADDR Tolerance (V)	CAN Address (Node #)
0	0	±0.1	Address stored in non-volatile memory
3/7 (0.43)	0	±0.1	1
6/7 (0.86)	0	±0.1	2
9/7 (1.3)	0	±0.1	3
...	...	±0.1	...
18/7 (2.57)	21/7 (3.0)	±0.1	62
21/7 (3.0)	21/7 (3.0)	±0.1	63

CAN BAUD (P1-6)

The CAN bit rate is set by applying the appropriate voltage to the CAN BAUD pin as given in the table below.

CAN BAUD Value (V)	CAN BAUD Tolerance (V)	CAN Bus Bit Rate (bits/s)
0	±0.388	Bit rate stored in non-volatile memory
1	±0.388	500k
2	±0.388	250k
3	±0.388	125k

MECHANICAL INFORMATION

P1 - Signal Connector

Connector Information	30-pin, 2.54 mm spaced, dual-row header
Mating Connector	Samtec: SSM-115-L-DV

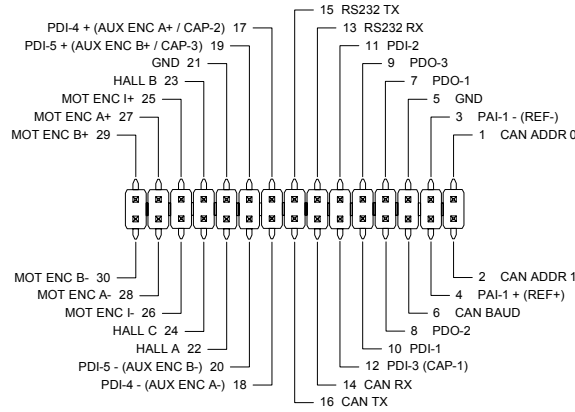

P2 - Power Connector

Connector Information	12-pin, 2.54 mm spaced header
Mating Connector	Samtec: BCS-112-L-S-PE

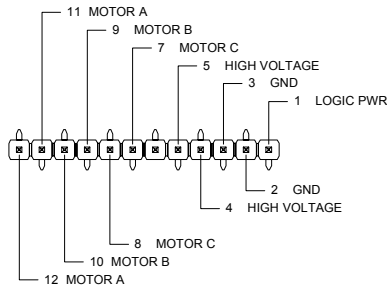

PART NUMBERING INFORMATION

Ex: **D Z R A L T E - 0 1 2 L 0 8 0**

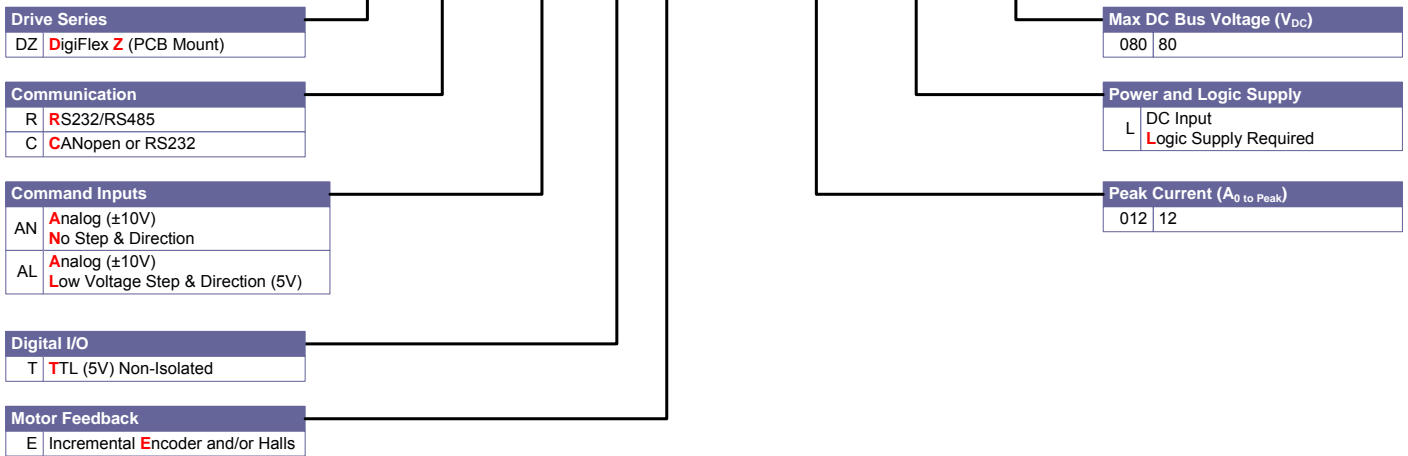

DigiFlex® Performance™ series of products are available in many configurations. All models listed on the website are readily available, standard product offerings. Other combinations or possibilities can be made available for OEMs with volume requests of 100 or more. Contact Applications Engineering for further information and details.

All specifications in this document are subject to change without written notice. Actual product may differ from pictures provided in this document.