

BD25A-AC SERIES BRUSHLESS SERVO AMPLIFIERS

Model: BD25A20AC

120 VAC, 50-60 Hz, Single Supply Operation

FEATURES:

- Surface-mount technology
- Small size, low cost, ease of use
- Input signal isolation
- Hall sensor input isolation
- Four quadrant regenerative operation
- Hall sensor commutation
- Agency Approvals:

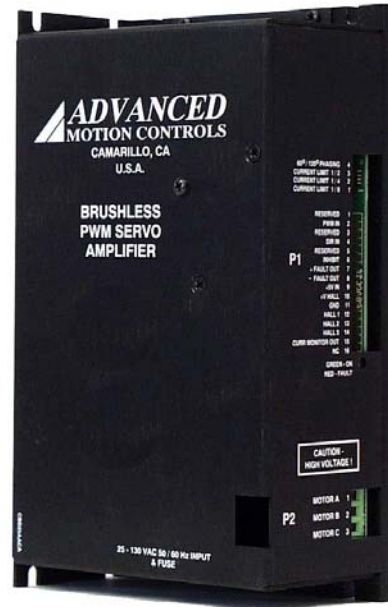

BLOCK DIAGRAM:

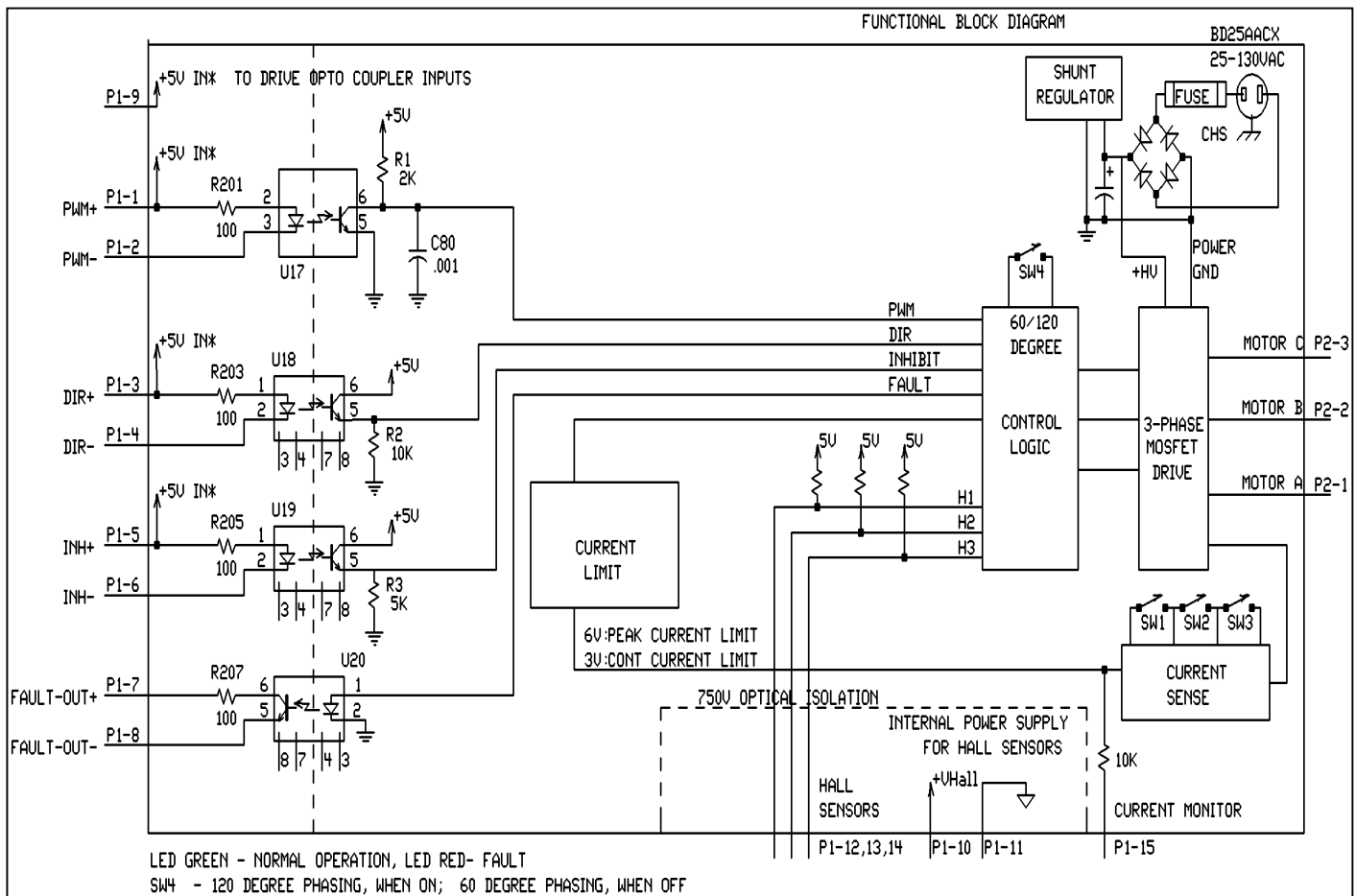

ADVANCED MOTION CONTROLS
 3805 Calle Tecate, Camarillo, CA 93012 Tel: (805) 389-1935, Fax: (805) 389-1165

DESCRIPTION: The BD25A20AC Series PWM servo amplifiers are designed to drive brushless DC motors at a high switching frequency. They are fully protected against over-voltage, over-current, over-heating and short-circuits. All models interface with digital controllers that have a digital PWM output. PWM IN determines the output duty cycle. DIR IN determines the direction of rotation. They require a single AC power supply. A single red/green LED indicates operating status. The current limit can be set by DIP switches.

SPECIFICATIONS:

All BD25A20AC specifications are identical to the BD25A20 specifications (see BD30A Series) except for:

	MODEL
POWER STAGE SPECIFICATIONS	BD25A20AC
AC SUPPLY VOLTAGE	30 - 125 VAC, 50 – 60 Hz
SHUNT RESISTOR	10 Ω @ 50 W
SHUNT SWITCH ON VOLTAGE	185 VDC
BUS CAPACITANCE	3600 μ F
SHUNT FUSE (d = .25 inches, L = 1.25 inches)	3 A Motor Delay rated @ 250 VAC
BUS FUSE (5x20 mm)	16 A slow-blow rated @ 250 VAC

MECHANICAL SPECIFICATIONS	
POWER CONNECTOR	Screw terminals
SIGNAL CONNECTOR	Molex connector
SIZE	7.35 x 4.23 x 2.45 inches 186.7 x 107.4 x 62.2 mm
WEIGHT	2.5 lb. 1.14 kg

These amplifiers contain a rectifier bridge and filter capacitors to generate the DC bus internally from the AC input power. The DC bus voltage is 1.4 times AC voltage (RMS), e.g. 170 VDC from 120 VAC. During braking much of the stored mechanical energy is fed back into the power supply and charges the output capacitor to a higher voltage. If the charge reaches the amplifier's over-voltage shutdown point, output current and braking will cease. To ensure smooth braking of large inertial loads, a built-in "shunt regulator" is provided in the BD25A20AC. The shunt regulator will switch-on the internal power resistor when the bus voltage reaches 185 VDC. This resistor then dissipates the extra energy of the DC bus.

APPLICATION NOTE: Contact factory for information regarding the use of the current monitor pin (P1-15).

OPTICAL INPUT SIGNAL ISOLATION: PWM, DIR, INH, FAULT inputs are always isolated from the power section. On the BD25A20AC series the Hall sensor inputs (P1-10 through 14) are also isolated.

ORDERING INFORMATION:

Models: BD25A20ACX
X indicates the current revision letter.

TYPICAL SYSTEM WIRING: See section "G".

MOUNTING DIMENSIONS: See page F-11.

BD30A SERIES BRUSHLESS SERVO AMPLIFIERS

Models: BD30A8, BD25A20

FEATURES:

- Surface-mount technology
- Small size, low cost, ease of use
- Input signal isolation
- Four quadrant regenerative operation
- Hall sensor commutation
- Agency Approvals:



BLOCK DIAGRAM:

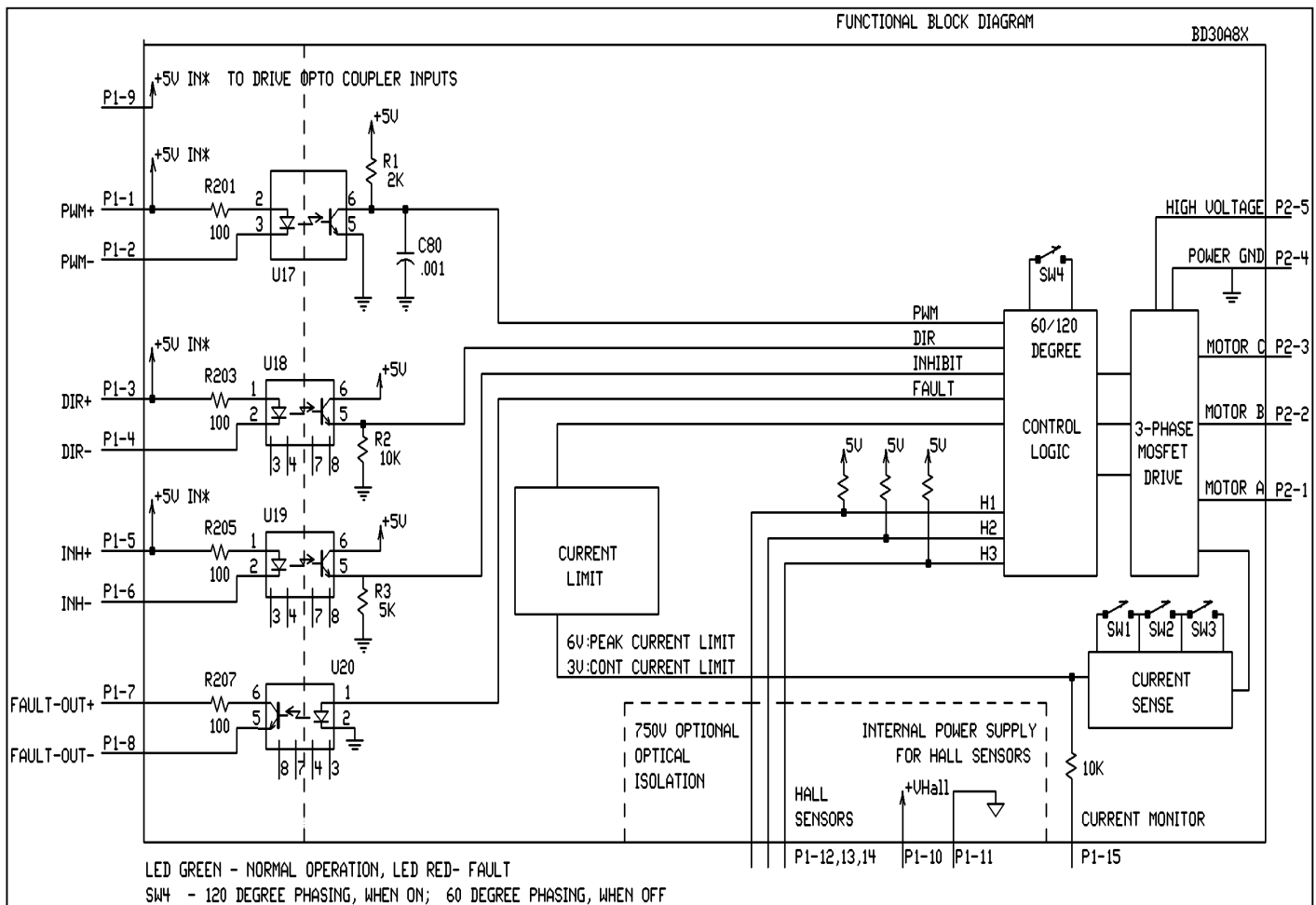

ADVANCED MOTION CONTROLS
 3805 Calle Tecate, Camarillo, CA 93012 Tel: (805) 389-1935, Fax: (805) 389-1165

DESCRIPTION: The BD30A Series PWM servo amplifiers are designed to drive brushless DC motors at a high switching frequency. They are fully protected against over-voltage, over-current, over-heating and short-circuits. All models interface with digital controllers that have a digital PWM output. PWM IN determines the output duty cycle. DIR IN determines the direction of rotation. A single red/green LED indicates operating status. The current limit can be set by DIP switches.

SPECIFICATIONS:

POWER STAGE SPECIFICATIONS	MODELS	
	BD30A8	BD25A20
DC SUPPLY VOLTAGE	20 - 80 V	40 - 190 V
PEAK CURRENT (2 sec. max., internally limited)	± 30 A	± 25 A
MAX. CONTINUOUS CURRENT (internally limited)	± 15 A	± 12.5 A
MINIMUM LOAD INDUCTANCE*	200 µH	250 µH
SWITCHING FREQUENCY	5 - 20 kHz ±15%	
HEATSINK (BASE) TEMPERATURE RANGE	0° to +65° C, disables if > 65° C	
POWER DISSIPATION AT CONT. CURRENT	60 W	125 W
OVER-VOLTAGE SHUT-DOWN (self reset)	86 V	195 V

MECHANICAL SPECIFICATIONS	
POWER CONNECTOR	Screw terminals
SIGNAL CONNECTOR	Molex connector
SIZE	7.35 x 4.40 x 1.00 inches 186.7 x 111.7 x 25.4 mm
WEIGHT	1.5 lb. 0.68 kg

* Low inductance motors require external inductors.

PIN FUNCTIONS:

CONNECTOR	PIN	NAME	DESCRIPTION / NOTES	I/O
P1	1	PWM+	Same as pin 9	I
	2	PWM-	Pulse width modulated digital input	I
	3	DIR+	Same as pin 9	I
	4	DIR-	Direction input	I
	5	INH+	Same as pin 9	I
	6	INH-	Pull low to enable	I
	7	+FAULT	Output transistor turns on and becomes high during output short circuit, over-voltage, over temperature, inhibit, and during power-up reset. Fault condition indicated by red LED.	O
	8	-FAULT		
	9	+5 IN	+5 V @ 150 mA in to drive opto coupler inputs.	I
	10	+V HALL OUT	Power for HALL sensors, Short circuit protected, + 6 V @ 30 mA. See optical signal isolation option below.	O
	11	GND		GND
	12	HALL 1	HALL sensor inputs, logic levels, internal 5 K Ω pull-up. Maximum low level input is 1.5 V, Minimum high level input is 3.5 V. See optical signal isolation option below.	I
	13	HALL 2		
	14	HALL 3		
	15	CURRENT MONITOR OUT	Current monitor. This signal is proportional to the actual current in the motor leads. See current limit adjustments section below for scaling.	O
	16	Reserved		
P2	1	MOTOR A	Motor phase A connection	O
	2	MOTOR B	Motor phase B connection	O
	3	MOTOR C	Motor phase C connection	O
	4	POWER GND	Power ground	GND
	5	HIGH VOLTAGE	DC power input	I

SET-UP: See section "G" for engineering and installation notes.

CURRENT LIMIT ADJUSTMENTS:

These amplifiers feature peak and continuous current limit adjustments. DIP switches reduce both peak and continuous current limit. The ratio of peak/continuous current limit is fixed (50%). The switches also adjust the scaling of CURR-MONITOR output.

SW1	SW2	SW3	Peak current (% of max.)	Continuous current (% of max. cont.)	Current Monitor Scaling
ON	ON	ON	100 %	100 %	4 A/V
ON	ON	OFF	50 %	50 %	2 A/V
ON	OFF	OFF	25 %	25 %	1 A/V
OFF	OFF	OFF	12.5 %	12.5 %	0.5 A/V

The actual current can be monitored at pin P1-15 and is referenced to POWER GND P2-4.

OPTICAL INPUT SIGNAL ISOLATION:

PWM, DIR, INH, FAULT inputs are always isolated from the power section. If the isolation option is selected the Hall sensor inputs (P1-10 through 14) are also isolated. If the isolated version is not ordered, an isolated power supply should be used with this series of amplifiers.

ORDERING INFORMATION:

Models: BD30A8X, BD25A20X

With isolation:

Models: BD30A8IX, BD25A20IX

X indicates the current revision letter.

MOUNTING DIMENSIONS: See page F-9.

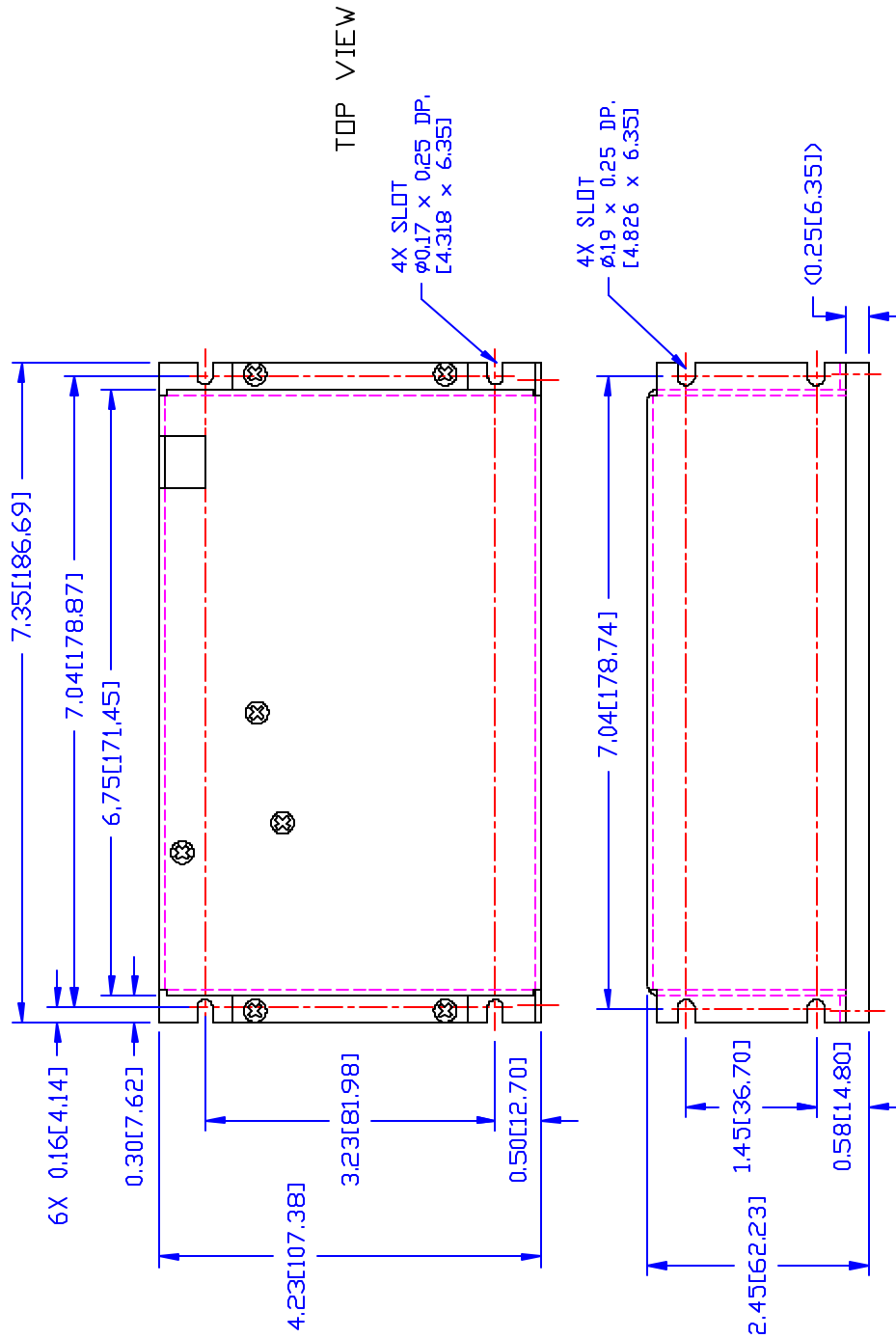

BACKSIDE VIEW

B	ADD BX25A20AC TO USED ON COLUMN	01/25/02	RB
A	UPDATE DWG. FORMAT & PICTORIAL	08/22/96	RB
REV	DESCRIPTION	DATE	BY

<p>ADVANCED MICROPOSITION CONTROLS • PWM SERVO AMPLIFIERS • 3805 Calle Tecate, Cananillo, CA 93012</p>	
TITLE MOUNTING DIMENSIONS B25A-AC & 30A-AC SERIES	
DRAWN BY: R. BAUTISTA	DATE: 10/06/95
CHECK BY:	DATE:
DESIGN APPROVED:	DATE:
USED ON BX25A20AC SERIES BE25A20AC SERIES B25A20AC SERIES BD25A-AC SERIES 30A-AC SERIES	SIZE DWG. NO. B MB25AAC
DO NOT SCALE DRAWING	SCALE: NONE
UNLESS OTHERWISE SPECIFIED: DIMENSIONS ARE IN INCHES TOLERANCES XX ± .010 XXX ± .005	SHT. 1 OF 1

NOTE: DIMENSIONS IN [] ARE IN MM.