

## BD15A SERIES BRUSHLESS SERVO AMPLIFIERS

### Model: BD15A8

**FEATURES:**

- Surface-mount technology
- Small size, low cost, ease of use
- Input signal isolation
- Four quadrant regenerative operation
- Hall sensor commutation
- Agency Approvals:



**BLOCK DIAGRAM:**

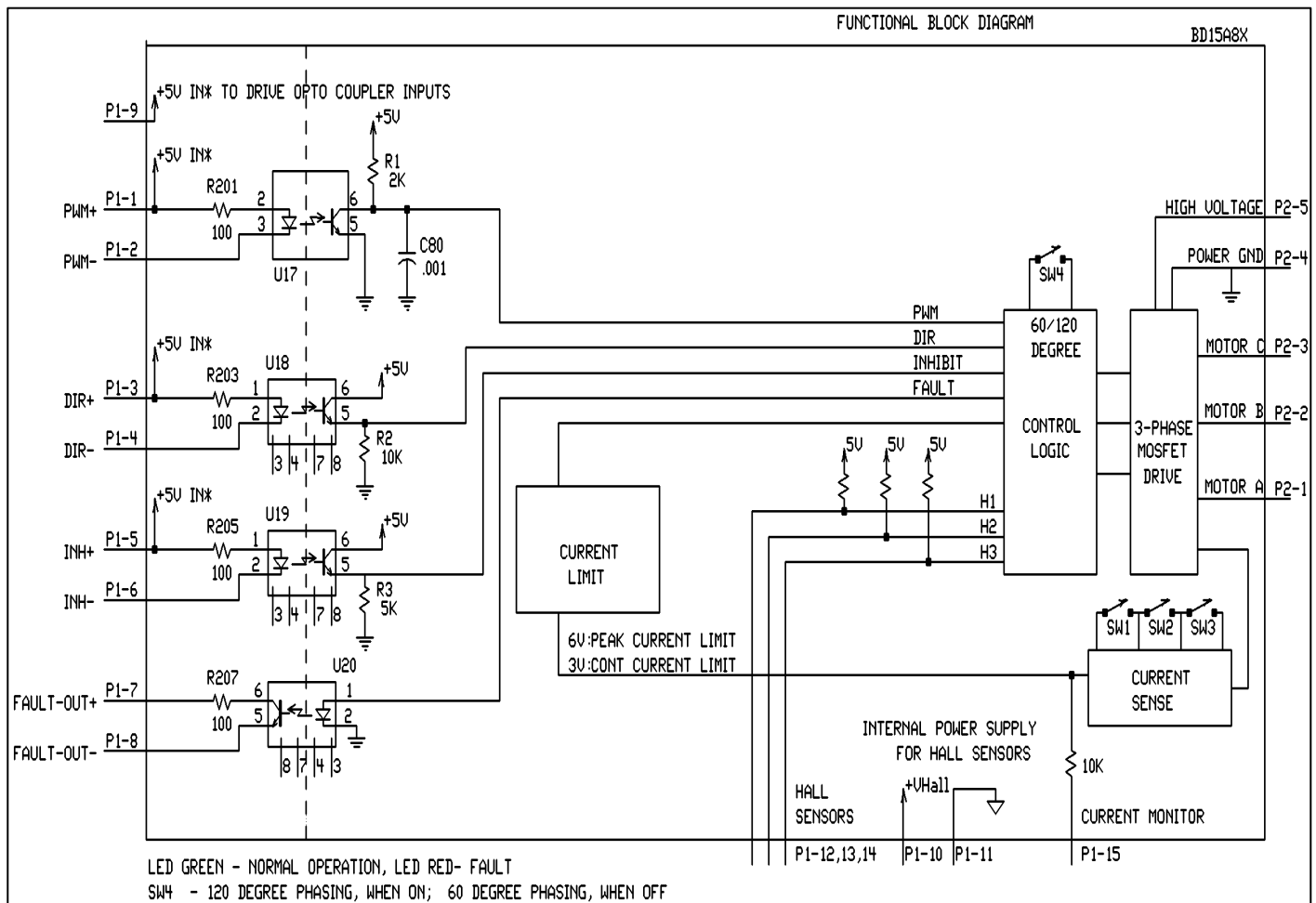

3805 Calle Tecate, Camarillo, CA 93012 Tel: (805) 389-1935, Fax: (805) 389-1165

**DESCRIPTION:** BD15A Series PWM servo amplifiers are designed to drive brushless DC motors at a high switching frequency. They are fully protected against over-voltage, over-current, over-heating and short-circuits. All models interface with digital controllers that have a digital PWM output. PWM IN determines the output duty cycle. DIR IN determines the direction of rotation. A single red/green LED indicates operating status. The current limit can be set by DIP switches.

**SPECIFICATIONS:**

<b>MODEL</b>	
<b>POWER STAGE SPECIFICATIONS</b>	BD15A8
DC SUPPLY VOLTAGE	20 - 80 V
PEAK CURRENT	± 15 A
MAXIMUM CONTINUOUS CURRENT	± 7.5 A
MINIMUM LOAD INDUCTANCE*	200 µH
SWITCHING FREQUENCY	5 - 20 kHz ±15%
HEATSINK (base) TEMPERATURE RANGE	0° to + 65°C, disables if > 65°C
POWER DISSIPATION AT CONTINUOUS CURRENT	30 W
OVER-VOLTAGE SHUT-DOWN (self reset)	85 V

<b>MECHANICAL SPECIFICATIONS</b>	
POWER CONNECTOR	Screw terminals
SIGNAL CONNECTOR	Molex connector
SIZE	5.09 x 2.98 x 0.99 inches 129.3 x 75.8 x 25.1 mm
WEIGHT	10 oz. 0.28 kg

\* Low inductance motors require external inductors.

## PIN FUNCTIONS:

CONNECTOR	PIN	NAME	DESCRIPTION / NOTES	I/O
P1	1	PWM+	Same as pin 9	I
	2	PWM-	Pulse width modulated digital input	I
	3	DIR+	Same as pin 9	I
	4	DIR-	Direction input	I
	5	INH+	Same as pin 9	I
	6	INH-	Pull low to enable	I
	7	+FAULT	Output transistor turns on and becomes high during output short circuit, over-voltage, over temperature, inhibit, and during power-up reset. Fault condition indicated by red LED.	O
	8	-FAULT		
	9	+5 IN	+5 V @ 150 mA in to drive opto coupler inputs.	I
	10	+V HALL OUT	Power for HALL sensors, short circuit protected, + 6 V @ 30 mA	O
	11	GND		GND
	12	HALL 1	HALL sensor inputs, logic levels, Internal 5 K $\Omega$ pull-up. Maximum low level input is 1.5 V, minimum high level input is 3.5 V	I
	13	HALL 2		
	14	HALL 3		
	15	CURRENT MONITOR OUT	Current monitor. This signal is proportional to the actual current in the motor leads. See current limit adjustments section below for scaling.	O
	16	Reserved		
P2	1	MOTOR A	Motor phase A connection	O
	2	MOTOR B	Motor phase B connection	O
	3	MOTOR C	Motor phase C connection	O
	4	POWER GND	Power ground	GND
	5	HIGH VOLTAGE	DC power input	I

**SET-UP:** See section "G" for engineering and installation notes.

**CURRENT LIMIT ADJUSTMENTS:**

These amplifiers feature peak and continuous current limit adjustments. DIP switches reduce both peak and continuous current limit. The ratio of peak/continuous current limit is fixed to 50%. The switches also adjust the scaling of CURR-MONITOR output.

SW1	SW2	SW3	Peak current (% of max.)	Continuous current (% of max. cont.)	Current Monitor
ON	ON	ON	100 %	100 %	2 A/V
ON	ON	OFF	50 %	50 %	1 A/V
ON	OFF	OFF	25 %	25 %	.5 A/V
OFF	OFF	OFF	12.5 %	12.5 %	0.25 A/V

The actual current can be monitored at pin P1-15 and is referenced to POWER GND P2-4.

**ORDERING INFORMATION:**

Models: BD15A8X

X indicates the current revision letter.

**MOUNTING DIMENSIONS:** See page F-7.

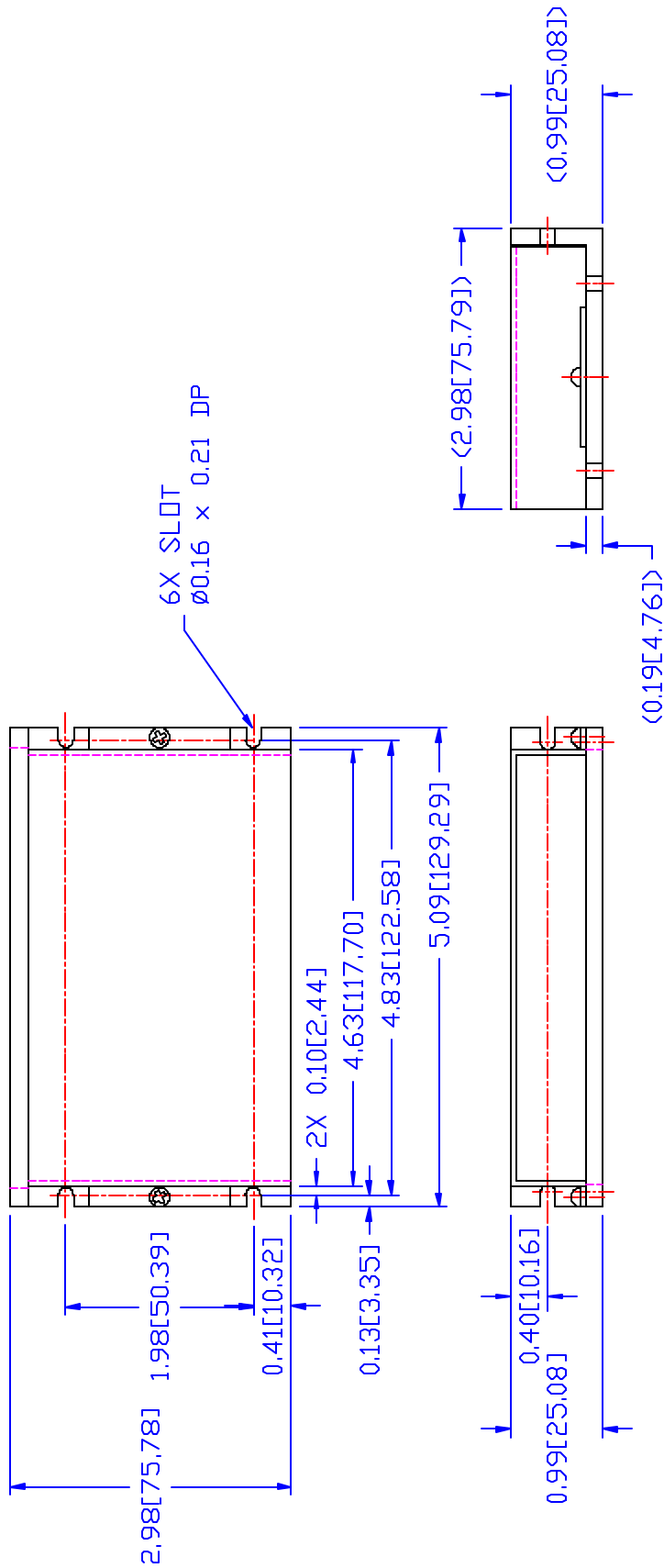

NOTE: DIMENSIONS IN [ ] ARE IN MM.

B	CHANGE ADDRESS ON TITLE BLOCK	09/18/01	RB
A	UPDATE DWG. FORMAT	08/22/96	RB
REV	DESCRIPTION	DATE	BY
UNLESS OTHERWISE SPECIFIED, DIMENSIONS ARE IN INCHES TOLERANCES .XX ± .010 .XXX ± .005 DO NOT SCALE DRAWING			
ADVANCED MOTION CONTROLS PWM SERVO AMPLIFIERS 9805 Calle Tecate, Cananillo, CA 95012			
TITLE MOUNTING DIMENSIONS			
B12A, 25A, BE12A SERIES			
DRAWN BY: ROBERTO		DATE: 09/27/95	REV
CHECK BY:		DATE:	B
DESIGN APPROVED:		DATE:	MB12A
SIZE DWG. NO. B			SCALE: NONE
USED ON			SHT. 1 OF 1