

## B40A40 SERIES BRUSHLESS SERVO AMPLIFIERS

### Model: B40A40

#### FEATURES:

- Surface-mount technology
- Small size, low cost, ease of use
- Optical isolation, see block diagram
- DIP switch selectable modes:  
current, open loop, external velocity,  
tach, Hall velocity and encoder velocity
- Four quadrant regenerative operation
- Agency Approvals:

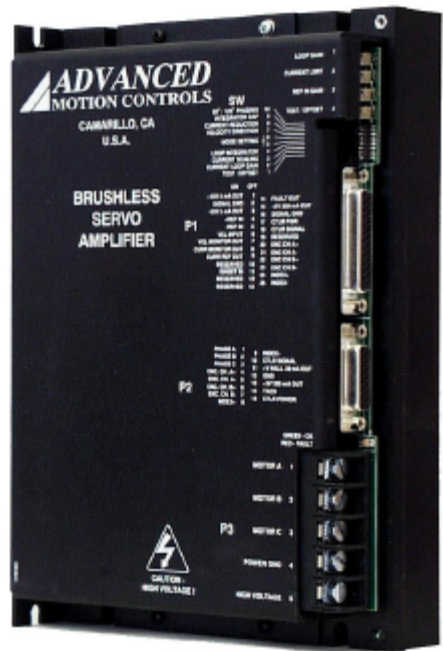

#### BLOCK DIAGRAM:

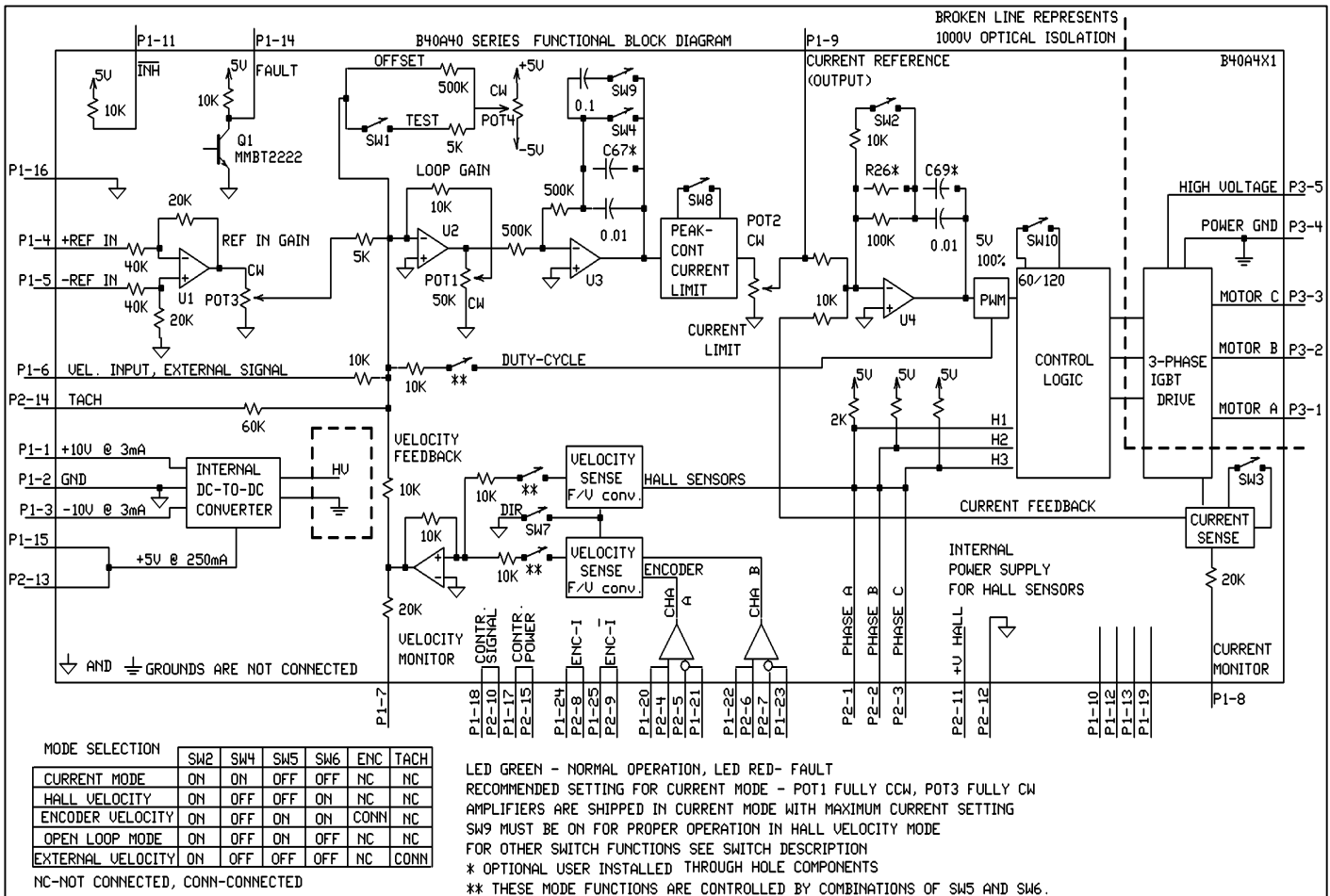

**DESCRIPTION:** B40A40 Series PWM servo amplifiers are designed to drive brushless DC motors at a high switching frequency. They are fully protected against over-voltage, under-voltage, over-current, over-heating and short-circuits. All models interface with digital controllers or can be used as stand-alone drives. They require only a single unregulated DC power supply. A single red/green LED indicates operating status. Loop gain, current limit, input gain and offset can be adjusted using 14-turn potentiometers. The offset adjusting potentiometer can also be used as an on-board input signal for testing purposes when SW1 (DIP switch) is ON.

**SPECIFICATIONS:**

	<b>MODEL</b>
<b>POWER STAGE SPECIFICATIONS</b>	<b>B40A40</b>
DC SUPPLY VOLTAGE	60 - 400 V
PEAK CURRENT (2 sec. max., internally limited)	± 40 A
MAX. CONTINUOUS CURRENT (internally limited)	± 20 A
MINIMUM LOAD INDUCTANCE*	600 µH
SWITCHING FREQUENCY	20 kHz ± 15%
HEATSINK (BASE) TEMPERATURE RANGE	0° to +65 °C, disables if > 65 °C
POWER DISSIPATION AT CONTINUOUS CURRENT	400 W
OVER-VOLTAGE SHUT-DOWN (self reset)	420 V
BANDWIDTH (load dependent)	2.5 kHz

<b>MECHANICAL SPECIFICATIONS</b>	
POWER CONNECTOR: P3	Screw terminals
SIGNAL CONNECTOR: P1, P2	P1 is a 25 pin and P2 is a 15 pin low density female D-Sub Connector
SIZE	9.24 x 6.28 x 2.51 inches 234.7 x 159.4 x 63.8 mm
WEIGHT	4.5 lb. 2.1 kg

\* Low inductance motors require external inductors.

## PIN FUNCTIONS:

CONNECTOR	PIN	NAME	DESCRIPTION / NOTES	I/O
P1	1	+10 V @ 3 mA OUT	For customer use	O
	2	SIGNAL GND	Reference ground	SGND
	3	-10 V @ 3 mA OUT	For Customer use	O
	4	+REF IN	Differential reference input, maximum $\pm 15$ V, 40K input resistance	I
	5	-REF IN		
	6	Velocity Input	Single Ended reference input, external velocity signal, maximum $\pm 15$ V, 10K input resistance	I
	7	VELOCITY MONITOR OUT	Hall-velocity mode: 1 V = 100 Hz Hall sensor frequency. Encoder velocity mode: 1V = 25 kHz encoder frequency.	O
	8	CURRENT MONITOR OUT	This signal is proportional to the actual current in the motor leads. SW3=OFF 1 V=2.75 A, SW3=ON 1V=5.5 A	O
	9	CURRENT REFERENCE OUT	Monitors the input signal connected directly to the internal current amplifier. 7.25 V = max peak current. See current limit adjustment information below.	O
	10	Reserved		
	11	INHIBIT IN	This TTL level input signal turns off all power devices of the "H" bridge when pulled to ground. This inhibit will cause a fault condition and a red LED. For inverted inhibit inputs, see section "G".	I
	12	Reserved		
	13	Reserved		
	14	FAULT OUT (LED red)	TTL level output. Becomes high during output SC, over and under-voltage, inhibit, and during power-up reset. Fault condition indicated by red LED.	O
	15	+5 V @ 250 mA OUT	For customer use. Note: the total current on P1-15 and P2-13 combined should not exceed 250 mA.	O
	16	SIGNAL GND	Reference ground	SGND
	17	Controller Power *	Connected to P2-15. For customer use	I
	18	Controller Signal *	Connected to P2-10. For customer use	I
	19	Reserved		
	20	Encoder Channel A+	Differential encoder output from P2-4.	O
	21	Encoder Channel A-	Differential encoder output from P2-5.	
	22	Encoder Channel B+	Differential encoder output from P2-6.	O
	23	Encoder Channel B-	Differential encoder output from P2-7.	
	24	Index +	Differential encoder output from P2-8 (Not Required).	O
	25	Index -	Differential encoder output from P2-9 (Not Required).	

## PIN FUNCTIONS:

CONNECTOR	PIN	NAME	DESCRIPTION / NOTES	I/O
P2	1	HALL 1	Hall sensor inputs, logic levels, internal 2K $\Omega$ pull-up. Maximum low level inputs is 1.5V, minimum high level inputs is 3.5 V	I
	2	HALL 2		
	3	HALL 3		
	4	Encoder Channel A+	Differential encoder input	I
	5	Encoder Channel A-		
	6	Encoder Channel B+	Differential encoder input	I
	7	Encoder Channel B-		
	8	Index+	Differential encoder input	I
	9	Index-		
	10	Controller signal *	Connected to P1-18. For customer use.	O
	11	+V HALL 30 mA OUT	Power for HALL sensors, short circuit protected, +6 V @ +30 mA	O
	12	GND		SGND
	13	+5V, 250mA OUT	For customer use. Note: the total current on P1-15 and P2-13 combined should not exceed 250 mA.	O
	14	TACH	Tachometer input, max. $\pm 60$ VDC, 60K input resistance	I
	15	Controller Power *	Connected to P1-17. For Customer Use.	O
P3	1	Motor A	Motor phase A connection	O
	2	Motor B	Motor phase B connection	O
	3	Motor C	Motor phase C connection	O
	4	POWER GND	Power ground	PGND
	5	HIGH VOLTAGE	DC power input	I

NOTES: All circuits on connectors P1 and P2 are optically isolated from all circuits on connector P3.

\* No Connection internal to amplifier. See block diagram.

**SWITCH FUNCTIONS:**

SWITCH	FUNCTION DESCRIPTION	SETTING	
		ON	OFF
1	Test / Offset. Sensitivity of the "offset" pot. Used as an on-board reference signal in test mode.	Test	Offset
2	Current loop gain	Decrease	Increase
3	Current scaling. When OFF, increases sensitivity of current sense thus reducing both peak and continuous current limit by 50%.	100%	50%
4	Loop integrator. This capacitor normally ensures "error-free" operation in velocity mode by reducing the error signal (output of summing amplifier) to zero.	Shorts out the velocity/voltage loop integrator capacitor	Velocity/voltage loop integrator operating
5	MODE SETTING	See chart in the functional block diagram	
6			
7	Velocity direction. Changes the polarity of the velocity monitor signal.		
8	Current reduction. Reduces continuous current limit by 50%.	Continuous / peak current limit ratio is 50%	Continuous / peak current limit ratio is 25%
9	Integrator capacitor. Adjusts the value of the integrator capacitor in velocity mode.	Increase	Decrease
10	60/120 degree commutation phasing setting	120 degree phasing	60 degree phasing

**POTENTIOMETER FUNCTIONS:**

POTENTIOMETER	DESCRIPTION	TURNING CW
Pot 1	Loop gain adjustment in open loop & velocity modes. Turn this pot fully ccw in current mode.	Increases loop gain
Pot 2	Current limit. It adjusts both continuous and peak current limit while maintaining selected ratio.	Increases current limit
Pot 3	Reference gain. It adjusts the ratio between input signal and output variables (voltage, current or velocity).	Increases reference input gain
Pot 4	Test / Offset. Used to adjust any imbalance in the input signal or in the amplifier. When SW1 (DIP switch) is OFF, the sensitivity of this pot is greatly increased thus it can be used as an on-board signal source for testing purposes. See section "G".	N/A

**TEST POINTS FOR POTENTIOMETERS:** See section "G".

### OPERATING MODE SELECTION:

These modes can be selected by the DIP switches according to the chart in the functional block diagram.

- Current mode
- Open loop mode
- Tachometer mode
- Hall velocity mode
- Encoder velocity mode

See section "G" for more information.

### SET-UP:

See section "G" for engineering and installation notes.

### CURRENT LIMIT ADJUSTMENTS:

These amplifiers feature separate peak and continuous current limit adjustments. Pot 2, the current limit potentiometer, adjusts both peak and continuous current limit at the same time. It has 12 active turns plus 1 inactive turn at each end and is approximately linear. Thus, to adjust the current limit turn the potentiometer counter-clockwise to zero, then turn clockwise to the appropriate value.

In many applications it is sufficient to use only the DIP switches for current limit adjustments. SW3 reduces both peak and continuous current limit by 50% when OFF. SW8 reduces only the continuous current limit by 50% when OFF:

SW8	CONTINUOUS / PEAK CURRENT LIMIT RATIO
ON	50%
OFF	25%

P1-9 is the input to the internal current amplifier stage. Since the output current is proportional to P1-9, the adjusted current limit can easily be observed at this pin without connecting the motor. Note that a command signal must be applied to the reference inputs to obtain a reading on P1-9. The maximum peak current value equals 7.25 V at this pin and the maximum continuous current value equals 3.63 V at this pin. If SW3=ON, peak rated amplifier current = 7.25 V. If SW3=OFF,  $\frac{1}{2}$ peak rated amplifier current = 7.25 V. Example: using the B40A40 with SW3=ON, 40A=7.25V and with SW3=OFF, 20A=7.25V.

The actual current can be monitored at pin P1-8.

### ORDERING INFORMATION:

Models: B40A40X

X indicates current revision letter.

**TYPICAL SYSTEM WIRING:** See section "G".

**MOUNTING DIMENSIONS:** See page F-15.

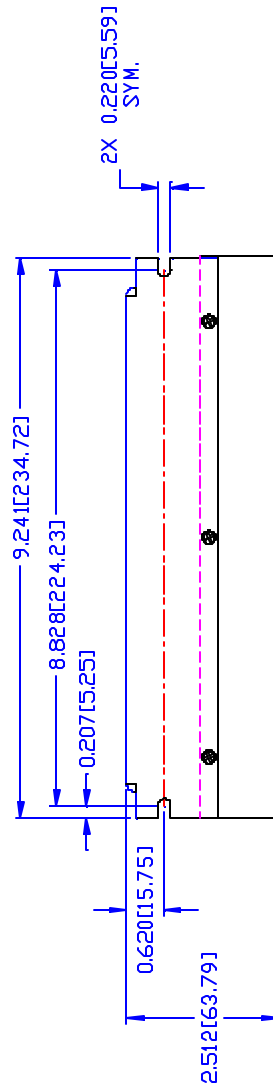
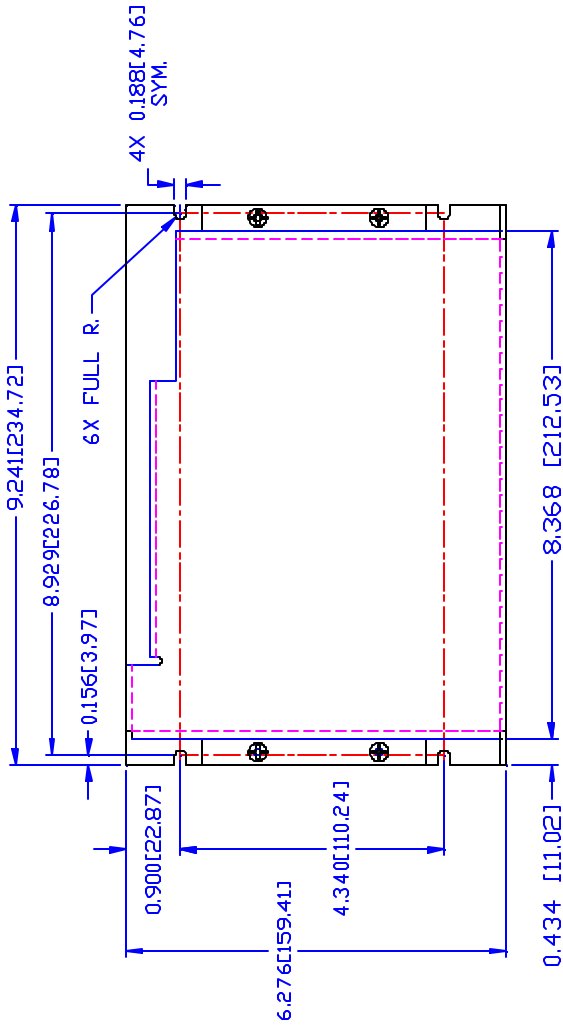
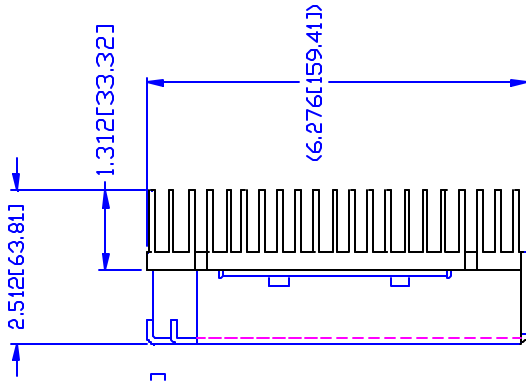

BACKSIDE VIEW

NOTE: DIMENSIONS IN [ ] ARE IN MM.

UNLESS OTHERWISE SPECIFIED, DIMENSIONS ARE IN INCHES		CHANGE ADDRESS ON TITLE BLOCK		02/12/02		RB	
TOLERANCES		DIM'S ARE 0.900, 4.34		08/03/98		RB	
.XX ± 0.01		VERE 0.046, 4.488		DATE		BY	
.XXX ± .005		DESCRIPTION		DATE		BY	
DO NOT SCALE DRAWING		ADVANCED		MOTION CONTROLS		MOUNTING DIMENSIONS, B40A40	
DRAWN BY: R BAUTISTA		DATE: 02/20/97		3805 Calle Tecate, Cananillo, CA 92012		TITLE	
CHECK BY:		DATE:		SIZE: DWG, ND, MDB40A		REV: B	
DESIGN APPROVED:		DATE:		SCALE: FULL		SHT. 1 OF 1	
B40A40 SERIES USED ON							