

## B100A-AC SERIES BRUSHLESS SERVO AMPLIFIERS

### Model: B100A40AC

#### FEATURES:

- Surface-mount technology
- Small size, low cost, ease of use
- Optical isolation, see block diagram
- DIP switch selectable modes:  
current, open loop, external velocity, tach,  
Hall velocity and encoder velocity
- Four quadrant regenerative operation
- Adjustable Accel/Decel Rate in Hall and  
Encoder velocity modes
- AC Supply Operation
- Agency Approvals:



#### BLOCK DIAGRAM:

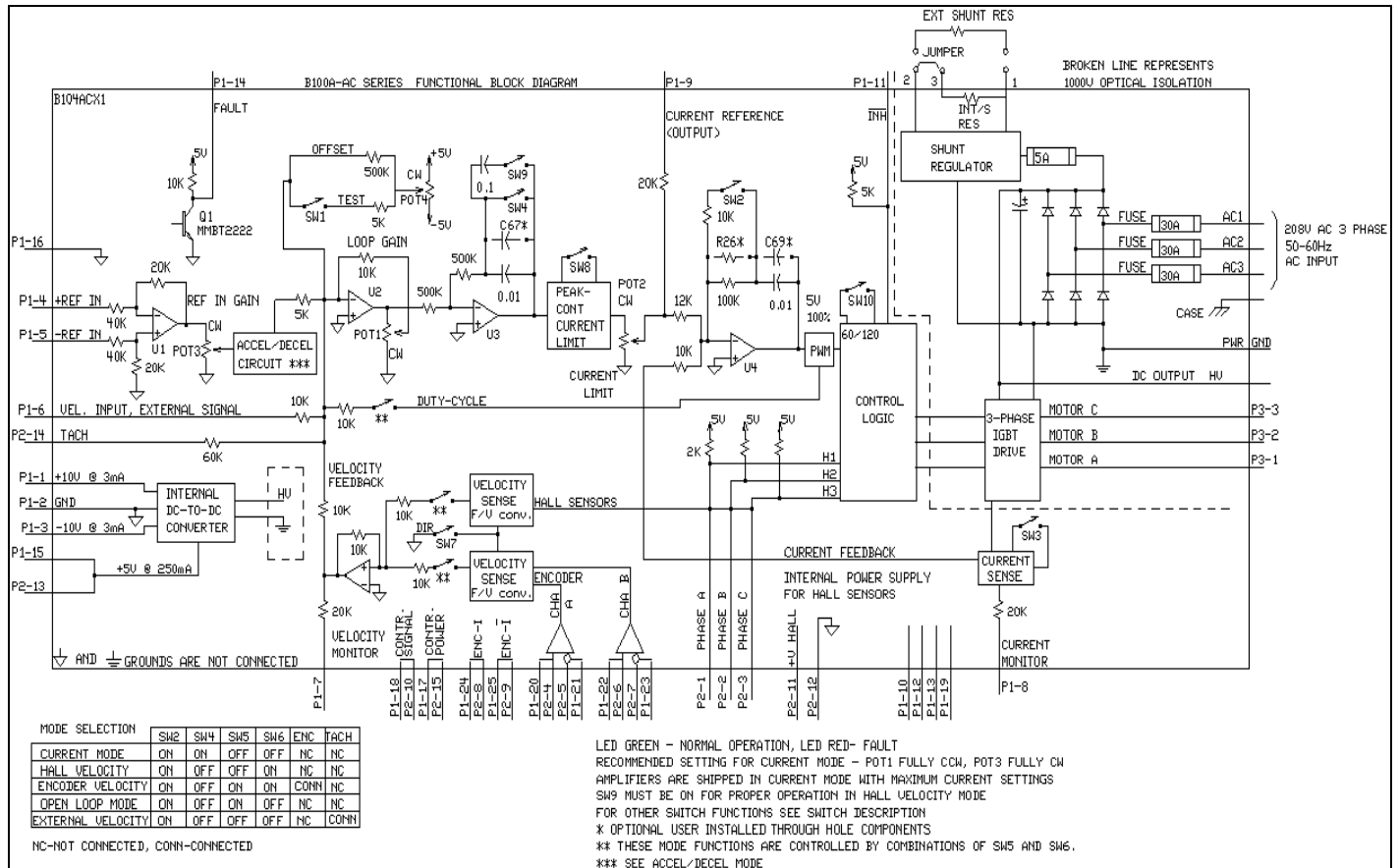

**ADVANCED MOTION CONTROLS**  
 3805 Calle Tecate, Camarillo, CA 93012

Tel: (805) 389-1935, Fax: (805) 389-1165

**DESCRIPTION:** The B100A40AC Series PWM servo amplifiers are designed to drive brushless DC motors at a high switching frequency. They are fully protected against over-voltage, under-voltage, over-current, over-heating and short-circuits. All models interface with digital controllers or can be used as stand-alone drives. They require only a single AC 3-phase power supply. A single red/green LED indicates operating status. Loop gain, current limit, input gain and offset can be adjusted using 14-turn potentiometers. The offset adjusting potentiometer can also be used as an on-board input signal for testing purposes when SW1 (DIP switch) is ON.

**SPECIFICATIONS:**

All B100A40AC specifications are identical to the B100A40 specifications (see B100A series data sheets) except for:

	MODEL
<b>POWER STAGE SPECIFICATIONS</b>	<b>B100A40AC</b>
THREE PHASE AC SUPPLY VOLTAGE	45-270 VAC @ 50-60 Hz
INTERNAL SHUNT RESISTOR	20 $\Omega$ @ 180 W
SHUNT SWITCH-ON VOLTAGE*	390 VDC
BUS CAPACITANCE	2,640 $\mu$ F
SHUNT FUSE (d=13/32 inches, L= 1½ inches)	5A time delay @ 500 VAC
AC LINE FUSES (d=13/32 inches, L= 1½ inches)	30A time delay @ 250 VAC

MECHANICAL SPECIFICATIONS	
SIGNAL CONNECTOR: P1, P2	P1 is a 25 pin and P2 is a 15 pin low density, female D-sub connector
POWER CONNECTOR: P3	Screw terminals
DC OUTPUT CONNECTOR	Screw terminals
EXTERNAL SHUNT RESISTOR CONNECTOR	Screw terminals
SIZE	10.65 x 9.20 x 6.32 inches 270.5 x 233.7 x 160.6 mm
WEIGHT	14.5 lb. 6.66 kg

\* If the shunt regulator is disabled the shut down voltage is 425 VDC.

These amplifiers contain a rectifier bridge and filter capacitors to generate the DC bus internally from the AC input power. The DC bus voltage is 1.4 times AC voltage (RMS), e.g. 310 VDC from 220 VAC. During braking much of the stored mechanical energy is fed back into the power supply and charges the output capacitor to a higher voltage. If the charge reaches the amplifier's over-voltage shutdown point, output current and braking will cease. To ensure smooth braking of large inertial loads, a built-in "shunt regulator" is provided in the B100A40AC. The shunt regulator will switch-on the power resistor when the bus voltage reaches 390 VDC (see also "Regenerative Operation" in Section G). This resistor then dissipates the extra energy of the DC bus. If the temperature of the case rises above 65 ° C, a thermal switch will disable the shunt regulator. As a result, the amplifier will operate without the shunt regulator and the over voltage protection on the amplifier will disable the drive if the regeneration energy causes the bus voltage to exceed 425 VDC.

An external shunt resistor can be added parallel to the internal resistor between pins 1 and 2 of the shunt screw terminal connector. Removing the jumper between pins 2 and 3 will disable the internal shunt resistor. These options are marked case silkscreen.

**ORDERING INFORMATION:**

Models: B100A40ACX

X indicates current revision letter.

**TYPICAL SYSTEM WIRING:** See section "G".

**MOUNTING DIMENSIONS:** See page F-21.

## B100A SERIES BRUSHLESS SERVO AMPLIFIERS

### Models: B100A8, B100A20, B100A40

**FEATURES:**

- Surface-mount technology
- Small size, low cost, ease of use
- Optical isolation, see block diagram
- DIP switch selectable modes:  
current, open loop, external velocity, tach,  
Hall velocity and encoder velocity
- Four quadrant regenerative operation
- Adjustable Accel/Decel Rate in Hall and  
Encoder velocity modes
- Agency Approvals:



**BLOCK DIAGRAM:**

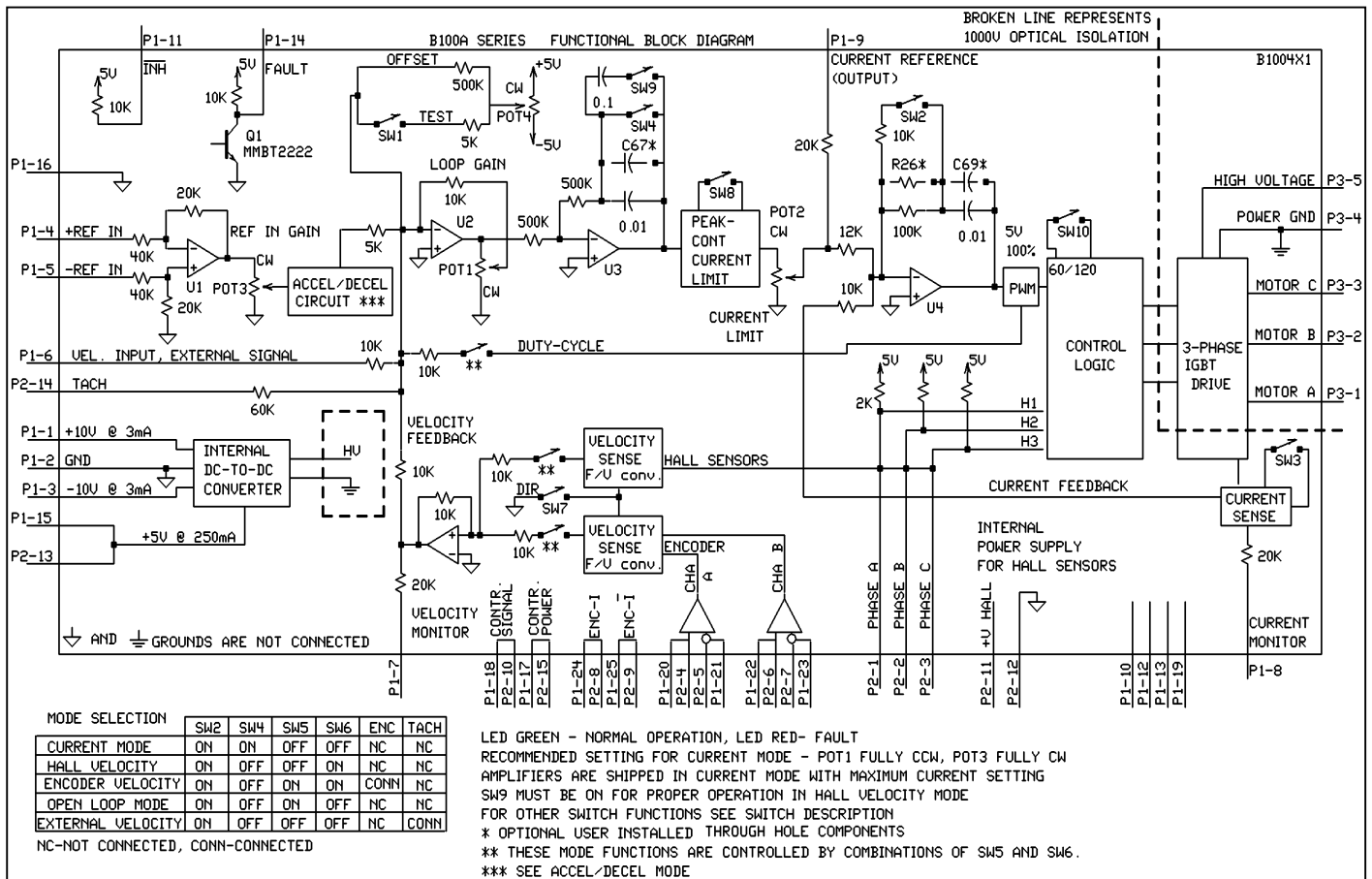

**DESCRIPTION:** The B100A Series PWM servo amplifiers are designed to drive brushless DC motors at a high switching frequency. They are fully protected against over-voltage, under-voltage, over-current, over-heating and short-circuits. All models interface with digital controllers or can be used as stand-alone drives. They require only a single unregulated DC power supply. A single red/green LED indicates operating status. Loop gain, current limit, input gain and offset can be adjusted using 14-turn potentiometers. The offset adjusting potentiometer can also be used as an on-board input signal for testing purposes when SW1 (DIP switch) is ON.

**SPECIFICATIONS:**

POWER STAGE SPECIFICATIONS	MODELS		
	B100A8	B100A20	B100A40
DC SUPPLY VOLTAGE	20 - 80 V	60 - 200 V	60 - 400 V
PEAK CURRENT (2 sec. max., internally limited)	± 100 A (70.7 Arms)	± 100 A (70.7 Arms)	± 100 A (70.7 Arms)
MAX. CONTINUOUS CURRENT (internally limited)	± 50 A (35.4 Arms)	± 50 A (35.4 Arms)	± 50 A (35.4 Arms)
MINIMUM LOAD INDUCTANCE*	200 µH	300 µH	600 µH
SWITCHING FREQUENCY	15 kHz ±15%		
HEATSINK (BASE) TEMPERATURE RANGE	0° to +65 °C, disables if > 65 °C		
POWER DISSIPATION AT CONTINUOUS CURRENT	200 W	500 W	1000 W
OVER-VOLTAGE SHUT-DOWN (self reset)	86 V	210 V	425 V
BANDWIDTH (load dependent)	2.5 kHz		

MECHANICAL SPECIFICATIONS	
POWER CONNECTOR: P3	Screw terminals
SIGNAL CONNECTOR: P1, P2	P1 is a 25 pin and P2 is a 15 pin low density, female D-sub connector
SIZE	10.65 x 9.20 x 3.64 inches 270.5 x 233.7 x 92.4 mm
WEIGHT	11.00 lb. 4.99 kg

\* Low inductance motors require external inductors.

**PIN FUNCTIONS:**

CONNECTOR	PIN	NAME	DESCRIPTION / NOTES	I/O
P1	1	+10 V@ 3 mA OUT	For customer use	O
	2	SIGNAL GND	Reference ground	SGND
	3	-10 V@ 3 mA OUT	For Customer use	O
	4	+REF IN	Differential reference input, maximum ±15 V, 50K input resistance	I
	5	-REF IN		
	6	Vel. Input	Single Ended reference input, external velocity signal, maximum ±15 V, 40K input resistance	I
	7	VELOCITY MONITOR OUT	Hall-velocity mode: 1 V=100 Hz Hall sensor frequency. Encoder velocity mode: 1 V = 25 kHz encoder frequency.	O
	8	CURRENT MONITOR OUT	This signal is proportional to the actual current in the motor leads. SW3=OFF 1V = 8A, SW3=ON 1 V = 16 A	O
	9	CURRENT REFERENCE OUT	Monitors the input signal connected directly to the internal current amplifier. 7.25 V = max peak current. See current limit adjustment information below.	O
	10	Reserved		
	11	INHIBIT IN	This TTL level input signal turns off all power devices of the "H" bridge when pulled to ground. This inhibit will cause a fault condition and a red LED. For inverted inhibit inputs, see section "G".	I
	12	Reserved		
	13	Reserved		
	14	FAULT OUT (LED red)	TTL level output. Becomes high during output SC, over and under-voltage, inhibit, and during power-up reset. Fault condition indicated by a red LED.	O
	15	+5 V @ 250 mA OUT	For customer use. Note: the total current on P1-15 and P2-13 combined should not exceed 250 mA.	O
	16	SIGNAL GND	Reference ground	SGND
	17	Controller Power *	Connected to P2-15. For customer use	I
	18	Controller Signal *	Connected to P2-10. For customer use	I
	19	Reserved		
	20	Encoder Channel A	Differential encoder output from P2-4.	O
	21	Encoder Channel A	Differential encoder output from P2-5.	
	22	Encoder Channel B	Differential encoder output from P2-6.	O
	23	Encoder Channel B	Differential encoder output from P2-7.	
	24	Index	Differential encoder output from P2-8 (Not Required).	O
	25	Index	Differential encoder output from P2-9 (Not Required).	

## PIN FUNCTIONS:

CONNECTOR	PIN	NAME	DESCRIPTION / NOTES	I/O
P2	1	HALL 1	Hall sensor inputs, logic levels, internal 2 K $\Omega$ pull-up. Maximum low level inputs is 1.5 V, minimum high level inputs is 3.5 V.	I
	2	HALL 2		
	3	HALL 3		
	4	Encoder Channel A	Differential encoder input	I
	5	Encoder Channel A		
	6	Encoder Channel B	Differential encoder input	I
	7	Encoder Channel B		
	8	Index +	Differential encoder input	I
	9	Index -		
	10	Controller signal *	Connected to P1-18. For customer use	O
	11	+V HALL @ 30 mA OUT	Power for HALL sensors, short circuit protected, +6 V @ +30 mA	O
	12	GND		SGND
	13	+5V @ 250 mA OUT	For customer use. Note: the total current on P1-15 and P2-13 combined should not exceed 250 mA.	O
	14	TACH	Tachometer input, 60 K $\Omega$ , $\pm$ 60 V MAX	I
	15	Controller Power *	Connected to P1-17. For customer use	O
P3	1	Motor A	Motor phase A connection	O
	2	Motor B	Motor phase B connection	O
	3	Motor C	Motor phase C connection	O
	4	POWER GND	Power ground	PGND
	5	HIGH VOLTAGE	DC power input	I

NOTES: All circuits on connectors P1 and P2 are optically isolated from all circuits on connector P3.

\* No Connection internal to amplifier. See block diagram.

**SWITCH FUNCTIONS:**

SWITCH	FUNCTION DESCRIPTION	SETTING	
		ON	OFF
1	Test / Offset. Sensitivity of the "offset" pot. Used as an on-board reference signal in test mode.	Test	Offset
2	Current loop gain	Decrease	Increase
3	Current scaling. When OFF, increases sensitivity of current sense thus reducing both peak and continuous current limit by 50%.	100%	50%
4	Loop integrator. This capacitor normally ensures "error-free" operation in velocity mode by reducing the error signal (output of summing amplifier) to zero.	Shorts out the velocity/voltage loop integrator capacitor	Velocity/voltage loop integrator operating
5	MODE SETTING	See chart in the functional block diagram	
6			
7	Velocity direction. Changes the polarity of the velocity monitor signal.		
8	Current reduction. Reduces continuous current limit by 50%.	Continuous / peak current limit ratio is 50%	Continuous / peak current limit ratio is 25%
9	Integrator capacitor. Adjusts the value of the integrator capacitor in velocity mode.	Increase	Decrease
10	60/120 degree commutation phasing setting	120 degree phasing	60 degree phasing

**POTENTIOMETER FUNCTIONS:**

POTENTIOMETER	DESCRIPTION	TURNING CW
Pot 1	Loop gain adjustment in open loop & velocity modes. Turn this pot fully ccw in current mode.	Increases loop gain
Pot 2	Current limit. It adjusts both continuous and peak current limit while maintaining selected ratio.	Increases current limit
Pot 3	Reference gain. It adjusts the ratio between input signal and output variables (voltage, current, velocity).	Increases reference input gain
Pot 4	Test / Offset. Used to adjust any imbalance in the input signal or in the amplifier. When SW1 (DIP switch) is ON, the sensitivity of this pot is greatly increased thus it can be used as an on-board signal source for testing purposes. See section "G".	N/A

**TEST POINTS FOR POTENTIOMETERS:** See section "G".

### OPERATING MODE SELECTION:

These modes can be selected by the DIP switches according to the chart in the functional block diagram.

- Current mode
- Open loop mode
- Tachometer mode
- Hall velocity mode
- Encoder velocity mode
- Accel/Decel Mode

See section "G" for more information.

### ADJUSTABLE ACCEL/DECEL RATE

The B100A series has built-in acceleration and deceleration when in Hall velocity or Encoder velocity modes. To enable Accel/Decel, set the jumpers according to the table.

ACCEL/DECEL	J8	J9
Enabled	Not installed	Installed
Disabled	Installed	Not installed

J8 and J9 are jumper locations on the PCB. These jumper locations are silk-screened on the PCB for easy identification.

The acceleration and deceleration rates can be set independently using through-hole resistors at locations R914, R915, R907, R908 ( see table below). The rates are based on + or – 10 Volts to the Reference inputs. The "Time" listed in the table below is the time it takes to reach the 10-Volt input. The ramping rates are linear with respect to time. For example, if the input were only 5 Volts, the time to ramp to this voltage would be half the time to ramp to 10 Volts. These locations are silk-screened on the PCB for easy identification.

Time (Seconds)	Acceleration		Deceleration	
	R914 (Ohms)	R915 (Ohms)	R907 (Ohms)	R908 (Ohms)
1	50K	50K	50K	50K
2	50K	20K	50K	20K
3*	10K	10K	10K	10K
4	500K	20K	500K	20K
5	50K	5K	50K	5K
6	500K	10K	500K	10K
7	50K	2K	50K	2K
8	50K	1K	50K	1K
9	20K	0.1K	20K	0.1K
10	100K	0.1K	100K	0.1K

\* = Default setting

**SET-UP:** See section "G" for engineering and installation notes.

**CURRENT LIMIT ADJUSTMENTS:**

These amplifiers feature separate peak and continuous current limit adjustments. The current limit adjustment Pot 2 adjusts both peak and continuous current limit at the same time. It has 12 active turns plus 1 inactive turn at each end and is approximately linear. Thus, to adjust the current limit turn the potentiometer fully counter-clockwise, then turn clockwise to the appropriate value.

In many applications it is sufficient to use only the DIP switches for current limit adjustments. SW3 reduces both peak and continuous current limit by 50% when OFF. SW8 reduces only the continuous current limit by 50% when OFF.

P1-9 is the input to the internal current amplifier stage. Since the output current is proportional to P1-9, the adjusted current limit can easily be observed at this pin without connecting the motor. Note that a command signal must be applied to the reference inputs to obtain a reading on P1-9. The maximum peak current value equals 7.25V at this pin and the maximum continuous current value equals 3.63V at this pin. If SW3=ON, peak rated amplifier current equals 7.25V. If SW3=OFF,  $\frac{1}{2}$  peak rated amplifier current equals 7.25V. Example: using the B100A20 with SW3=ON, 100A=7.25V and with SW3=OFF, 50A=7.25V.

The actual current can be monitored at pin P1-8.

**ORDERING INFORMATION:**

Models: B100A8, B100A20X, B100A40X

X indicates current revision letter.

**TYPICAL SYSTEM WIRING:** See section "G".

**MOUNTING DIMENSIONS:** See page F-21.



