

SERIES 50A SERVO AMPLIFIERS

Models: 30A8, 25A20, 50A8, 50A20

FEATURES:

- Surface-mount technology
- Small size, low cost, ease of use
- Optional input signal isolation for off-the-rectified 120 VAC line operation
- DIP switch selectable: current, voltage, velocity, IR compensation, analog position loop
- Four quadrant regenerative operation
- Agency Approvals:



BLOCK DIAGRAM:

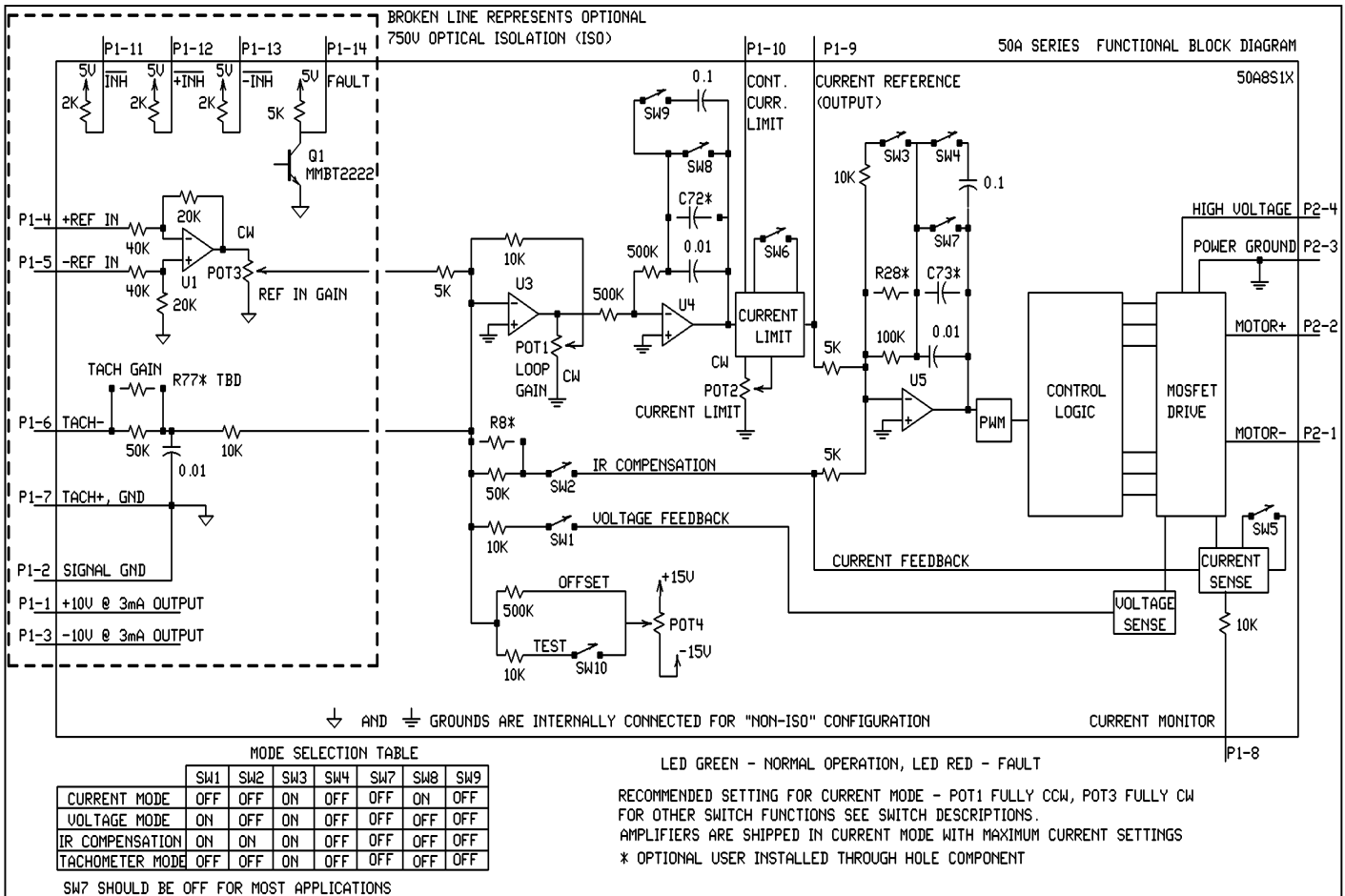

DESCRIPTION: The 50A Series PWM servo amplifiers are designed to drive brush type DC motors. A single red/green LED indicates operating status. All models are fully protected against over-voltage, over-current, over-heating and short-circuits across motor, ground and power leads. All models interface with digital controllers or can be used as a stand-alone drive. They require only a single unregulated DC power supply. Loop gain, current limit, input gain and offset can be adjusted using 14-turn potentiometers. The offset adjusting potentiometer can also be used as an on-board input signal for testing purposes when SW10 (DIP switch) is ON.

SPECIFICATIONS:

POWER STAGE SPECIFICATIONS	MODELS			
	30A8	25A20	50A8	50A20
DC SUPPLY VOLTAGE	20 - 80 V	40 - 190 V	20 - 80 V	40 - 190 V
PEAK CURRENT (2 sec. max., internally limited)	± 30 A	± 25 A	± 50 A	± 50 A
MAX. CONTINUOUS CURRENT (internally limited)	± 15 A	± 12.5 A	± 25 A	± 25 A
MINIMUM LOAD INDUCTANCE*	200 µH	250 µH	200 µH	250 µH
SWITCHING FREQUENCY	22 kHz ± 15%			
HEATSINK (BASE) TEMPERATURE RANGE	0° to +65° C, disables if > 65° C			
POWER DISSIPATION AT CONTINUOUS CURRENT	60 W	125 W	100 W	250 W
OVER-VOLTAGE SHUT-DOWN (self-reset)	86 V	195 V	86 V	195 V
BANDWIDTH (load dependent)	2.5 kHz			

MECHANICAL SPECIFICATIONS	
POWER CONNECTOR	Screw terminals
SIGNAL CONNECTOR	Molex connector
SIZE	7.35 x 4.40 x 1.00 inches 186.7 x 111.7 x 25.4 mm
WEIGHT	1.5 lb. 0.68 kg

* Low inductance motors ("pancake" and "basket-wound") require external inductors.

PIN FUNCTIONS:

CONNECTOR	PIN	NAME	DESCRIPTION / NOTES	I/O
P1	1	+10 V OUT	Provides regulated voltages of ± 10 V @ 3 mA for customer use. Short circuit protected.	O
	2	SIGNAL GND		SGND
	3	-10 V OUT		O
	4	+REF IN	Differential analog input, max ± 15 V, 40K input resistance.	I
	5	-REF IN		
	6	-TACH IN	Maximum ± 60 V analog, 60K input resistance.	I
	7	+TACH (SGND)		
	8	CURRENT MONITOR OUT	This signal is proportional to the actual current in the motor leads. Scaling is 4A/V (2A/V when SW5=OFF) for 30A8 and 25A20; and 8.1A/V (4.05A/V when SW5 = OFF) for 50A8 and 50A20.	O
	9	CURRENT REFERENCE OUT	Command signal to the internal current-loop. The maximum peak current rating of the amplifier always equals 7.25 V at this pin. See current limit adjustment information below.	O
	10	CONTINUOUS CURRENT LIMIT	Can be used to reduce the factory-preset maximum continuous current limit. See current limit adjustment information below. This is only an option on non-isolated units. This pin is reserved on isolated units.	I
	11	INHIBIT	This TTL level input signal turns off all four power devices of the "H" bridge drive when pulled to ground. This inhibit will cause a FAULT condition and a red LED. For inverted inhibit inputs; see the Engineering and Installation notes on the Advanced Motion Controls website.	I
	12	+INHIBIT	Disables the amplifier for the "+" direction only. This inhibit will not cause a FAULT condition or a red LED.	I
	13	-INHIBIT	Disables the amplifier for the "-" direction only. This inhibit will not cause a FAULT condition or a red LED.	I
	14	FAULT OUT (red LED)	TTL compatible output. It becomes high during output short-circuit, over-voltage, over-heating, inhibit, and during "power-on reset". Fault condition indicated by red LED.	O
	15	SYNCH IN	Used for synchronizing the switching frequency of several amplifier modules. Consult factory for this option. Not applicable for "ISO" option. On the "ISO" option pin 16 is connected to power ground and can be used as ground with P1-8 and P1-9. Pin 15 is reserved on "ISO" units.	N/A
	16	SYNCH OUT		
P2	1	- MOTOR	Motor minus connection.	O
	2	+MOTOR	Motor plus connection.	O
	3	POWER GROUND	Power Ground.	PGND
	4	HIGH VOLTAGE	DC voltage input.	I

SWITCH FUNCTIONS:

SWITCH	FUNCTION DESCRIPTION	SETTING	
		ON	OFF
1	Internal voltage feedback	On	Off
2	Internal current feedback for IR compensation	On	Off
3	Current loop gain	Decrease	Increase
4	Current loop integration	Increase	Decrease
5	Current scaling. When OFF, increases sensitivity of current sense thus reducing both peak and continuous current limit by 50% (see the Engineering and Installation notes on the Advanced Motion Controls website)	Full-current	Half-current
6	Can be used to reduce factory-preset maximum continuous current limit (see the Engineering and Installation notes on the Advanced Motion Controls website).	Cont./Peak Ratio 25%	Cont./Peak Ratio 50%
7	It is recommended to leave SW7 in the OFF position.	Shorts out the current loop integrator capacitor	Current loop integrator operating
8	This capacitor normally ensures "error-free" operation by reducing the error-signal (output of summing amplifier) to zero.	Shorts out the outer velocity / voltage loop integrator capacitor	Velocity/ Voltage integrator operating
9	Adjusts the value of the integrator capacitor. It is recommended to leave SW9 in the OFF position for most applications.	Increase	Decrease
10	Offset / test. Controls sensitivity of the "offset" pot. Used as an on-board reference signal in test mode.	Increase	Decrease

POTENTIOMETER FUNCTIONS:

POTENTIOMETER	DESCRIPTION	TURNING CW
Pot 1	Loop gain adjustment in voltage & velocity modes. Turn this pot fully ccw in current mode.	Increases loop gain
Pot 2	Current limit. It adjusts both continuous and peak current limit by maintaining their ratio (50%).	Increases current limit
Pot 3	Reference gain. It adjusts the ratio between input signal and output variables (voltage, current, and velocity).	Increases reference input gain
Pot 4	Offset / test. Used to adjust any imbalance in the input signal or in the amplifier. When SW10 (DIP switch) is ON, the sensitivity of this pot is greatly increased thus it can be used as an on-board signal source for testing purposes. See the Engineering and Installation notes on the Advanced Motion Controls website.	N/A

TEST POINTS FOR POTENTIOMETERS: See the Engineering and Installation notes on the Advanced Motion Controls website.

SET-UP: See the Engineering and Installation notes on the Advanced Motion Controls website.

OPTIONAL INPUT SIGNAL ISOLATION:

These amplifiers can be ordered with an internally installed analog isolation amplifier, which optically isolates the inputs from the remainder of the amplifier circuitry ("ISO" option). See functional block diagram above. This optional input isolation facilitates off-the-rectified-line operation. Isolation is necessary in transformer-less applications to isolate controller signal ground (often the same as earth ground) from DC power ground. The isolation option may also reduce system noise. This option is generally not required with isolated power supplies.

OPERATING MODE SELECTION:

These modes can be selected with the DIP switches according to the chart in the functional block diagram:

- Current Mode
- Voltage Mode
- IR Compensation Mode
- Tachometer Mode

See the Engineering and Installation notes on the Advanced Motion Controls website for more information.

APPLICATION NOTE:

See the Engineering and Installation notes on the Advanced Motion Controls website for more information on analog position loop mode.

CURRENT LIMIT ADJUSTMENTS:

These amplifiers feature separate peak and continuous current limit adjustments.

The current limit adjusting Pot 2 adjusts both peak and continuous current limit at the same time. It has 12 active turns plus 1 inactive turn at each end and is approximately linear. Thus, to adjust the current limit, turn the potentiometer fully counter-clockwise then turn clockwise to the appropriate value. If the desired limit is, for example, 25 amperes, and the servo amplifier peak current is 50 amperes, turn the potentiometer 7 turns clockwise from the fully counter-clockwise position.

Pin P1-9 is the input to the internal current amplifier stage. Since the output current is proportional to P1-9, the adjusted current limit can easily be observed at this pin. Note that a command signal must be applied to the reference inputs to obtain a reading on P1-9. The maximum peak current value equals 7.25 V at this pin and the maximum continuous current value equals 3.63 V at this pin. If SW5=ON, peak rated amplifier current=7.25 V. If SW5=OFF, 1/2 peak rated amplifier current =7.25 V. Example using the 30A8 with SW5=ON, 30 A=7.25 V and with SW5=OFF, 15 A=7.25 V.

The actual current can be monitored at pin P1-8.

The continuous current limit can be reduced without affecting the peak current limit by connecting an external current limiting resistor R-lmt between P1-10 and P1-2. This option is only available on non isolated units. See table below.

Current Limit Resistor (Ω)	18K	6.5K	3.4K	2.5K	1.8K	1K	800	300	0
Continuous Current Limit %	90%	80%	70%	65%	60%	50%	45 %	40 %	30 %

MC/MF Series

SW6 (DIP switch) will reduce the continuous current limit to 50% of the maximum value, when switched ON. SW5 (DIP switch) will reduce the current feedback (monitor) scaling by 50%, thereby reducing both the peak and the continuous current limit by 50%, when switched OFF.

TYPICAL SYSTEM WIRING: See the Engineering and Installation notes on the Advanced Motion Controls website.

ORDERING INFORMATION:

Models: 30A8X, 25A20X, 50A8X, 50A20X

With isolation: 30A8IX, 25A20IX, 50A8IX, and 50A20IX

X indicates the current revision letter.

MOUNTING DIMENSIONS: See page F-9.