

SERIES 30A-AC SERVO AMPLIFIERS

Models: 30A20AC, 16A20AC

120VAC, 50-60 Hz Single Supply Operation

FEATURES:

- Surface-mount technology
- Small size, low cost, ease of use
- Built-in optical isolation, see block diagram
- Shunt regulator (30A20AC only)
- DIP switch selectable: current, voltage, velocity, IR compensation, analog position loop
- Four quadrant regenerative operation
- Agency Approvals:



BLOCK DIAGRAM:

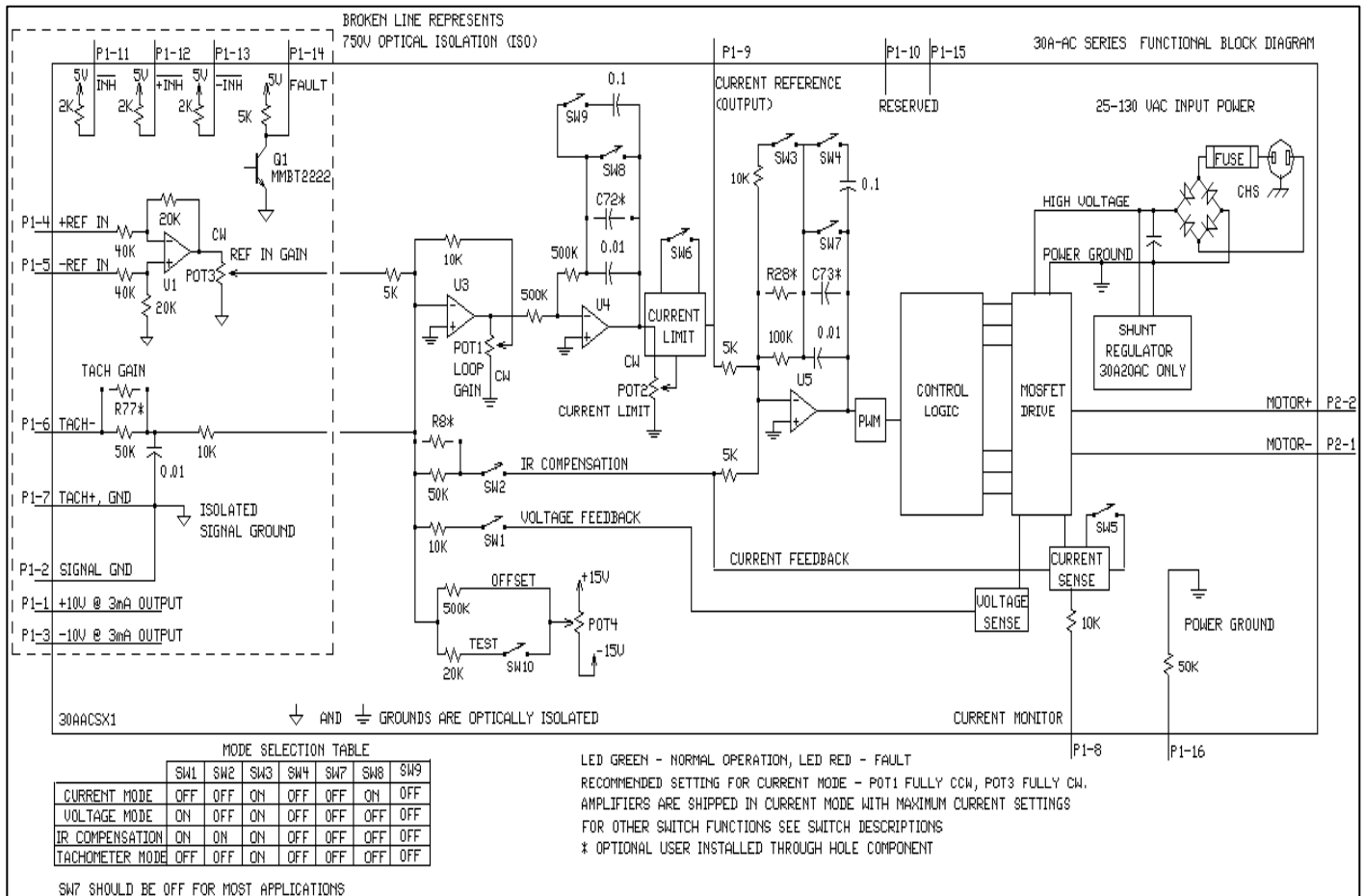

30A-AC Series

DESCRIPTION: The 30A-AC Series PWM servo amplifiers are designed to drive brush type DC motors at a high switching frequency. A single red/green LED indicates operating status. All models are fully protected against over-voltage, over-current, over-heating and short-circuits across motor, ground and power leads. These models interface with digital controllers or can be used as a stand-alone system. They require only a single AC power supply. Loop gain, current limit, input gain and offset can be adjusted using 14-turn potentiometers. The offset adjusting potentiometer can also be used as an on-board input signal for testing purposes when SW10 (DIP switch) is ON.

POWER STAGE SPECIFICATIONS	MODELS	
	30A20AC	16A20AC
SINGLE PHASE AC SUPPLY VOLTAGE *	30 – 125 VAC @ 50 - 60 Hz	
PEAK CURRENT (2 sec. Max., internally limited)	± 30 A	± 16 A
MAXIMUM CONTINUOUS CURRENT (internally limited)	± 15 A	± 8 A
MINIMUM LOAD INDUCTANCE**	250 µH	250 µH
SWITCHING FREQUENCY	22 kHz ± 15%	
HEATSINK (BASE) TEMPERATURE RANGE	0° to +65° C, disables if > 65° C	
POWER DISSIPATION AT CONTINUOUS CURRENT	150 W	80 W
OVER-VOLTAGE SHUT-DOWN (self-reset)	195 VDC	
BANDWIDTH (load dependent)	2.5 kHz	
SHUNT RESISTOR (30A20AC)	10 Ω @ 50 W	N/A
SHUNT REGULATOR TRIP VOLTAGE (30A20AC)	185 V = On, 180 V = Off	N/A
BUS CAPACITANCE	3600 µF	
SHUNT FUSE (d = .25 inches, L = 1.25 inches)	3 A, 250 VAC Motor Delay	N/A
BUS FUSE (5 X 20 mm)	15 A slow-blow rated @ 250 VAC	

MECHANICAL SPECIFICATIONS	
POWER CONNECTOR	Screw terminals
SIGNAL CONNECTOR	Molex connector
SIZE	7.35 x 4.23 x 2.45 inches 186.7 x 107.4 x 62.2 mm
WEIGHT	2.5 lb. 1.14 kg

* Do not exceed 125 VAC input.

**Low inductance motors ("pancake" and "basket-wound") require external inductors.

These amplifiers contain a rectifier bridge and filter capacitors to generate the DC bus internally from the AC input power. The DC bus voltage is 1.4 times AC voltage (RMS), e.g. 170 VDC from 120 VAC. During braking much of the stored mechanical energy is fed back into the power supply and charges the output capacitor to a higher voltage. If the charge reaches the amplifier's over-voltage shutdown point, output current and braking will cease. To ensure smooth braking of large inertial loads a built-in shunt regulator is provided in model 30A20AC. The shunt regulator will switch on the internal power resistor when the bus voltage reaches 185 VDC. This resistor then dissipates the extra energy of the DC bus.

PIN FUNCTIONS:

CONNECTOR	PIN	NAME	DESCRIPTION / NOTES	I/O
P1	1	+10V OUT	Outputs regulated voltages of ± 10 V @ 3 mA for customer use. Short circuit protected. Pin P1-2 is signal ground.	O
	2	SIGNAL GND		SGND
	3	-10V OUT		O
	4	+REF IN	Differential analog input, maximum ± 15 V, 40K input resistance.	I
	5	-REF IN		
	6	-TACH IN	Maximum ± 60 VDC, 60K input resistance.	I
	7	+TACH (SGND)		
	8	CURRENT MONITOR OUT	This signal is proportional to the actual current in the motor leads. Scaling is 4A/V (2A/V when SW5 = OFF) for 16A20AC; and 8A/V (4A/V when SW5 = OFF) for 30A20AC. See current limit adjustment information below. Referenced to P1-16.	O
	9	CURRENT REFERENCE OUT	Command signal to the internal current-loop. The maximum peak current rating of the amplifier always equals 7.25V. See current limit adjustment information below. Referenced to P1-16.	O
	10	Reserved		
	11	INHIBIT	This TTL level input signal turns off all four power devices of the "H" bridge drive when pulled to ground. This inhibit will cause a FAULT condition and a red LED. For inverted inhibit inputs; see section "G".	I
	12	+INHIBIT	Disables the amplifier for the "+" direction only. This inhibit will not cause a FAULT condition or a red LED.	I
	13	-INHIBIT	Disables the amplifier for the "-" direction only. This inhibit will not cause a FAULT condition or a red LED.	I
	14	FAULT OUT (red LED)	TTL compatible output. It becomes high during output short-circuit, over-voltage, over-heating, inhibit, and during "power-on reset". Fault condition indicated by a red LED.	O
	15	Reserved		
	16	NON-ISO GND	Connected to power ground and can be used as ground with P1-8 and P1-9.	PGND

SWITCH FUNCTIONS:

SWITCH	FUNCTION DESCRIPTION	SETTING	
		ON	OFF
1	Internal voltage feedback	On	Off
2	Internal current feedback for IR compensation	On	Off
3	Current loop gain	Decrease	Increase
4	Current loop integration	Increase	Decrease
5	Current scaling. When OFF, increases sensitivity of current sense thus reducing both peak and continuous current limit by 50%.	Full-current	Half-current
6	Can be used to reduce factory-preset maximum current limit.	Cont./Peak Ratio 25%	Cont./Peak Ratio 50%
7	It is recommended to leave SW7 in the OFF position.	Shorts out the current loop integrator capacitor	Current loop integrator operating
8	This capacitor normally ensures "error-free" operation by reducing the error-signal (output of summing amplifier) to zero.	Shorts out the outer velocity / voltage loop integrator capacitor.	Velocity/ Voltage integrator operating.
9	Adjusts the value of the integrator capacitor. It is recommended to leave SW9 in the OFF position for most applications.	Increase	Decrease
10	Offset / test. Controls sensitivity of the "offset" pot. Used as an on-board reference signal in test mode.	Test	Offset

POTENTIOMETER FUNCTIONS:

POTENTIOMETER	DESCRIPTION	TURNING CW
Pot 1	Loop gain adjustment in voltage & velocity modes. Turn this pot fully ccw in current mode.	Increases loop gain
Pot 2	Current limit. It adjusts both continuous and peak current limit by maintaining their ratio (50%).	Increases current limit
Pot 3	Reference gain. It adjusts the ratio between input signal and output variables (voltage, current, and velocity).	Increases reference input gain
Pot 4	Offset / test. Used to adjust any imbalance in the input signal or in the amplifier. When SW10 (DIP switch) is ON, the sensitivity of this pot is greatly increased thus it can be used as an on-board signal source for testing purposes. See section "G".	N/A

TEST POINTS FOR POTENTIOMETERS: See section "G"

SET-UP: See section "G" for engineering and installation notes.

STANDARD INPUT SIGNAL ISOLATION:

These amplifiers feature an internally installed analog isolation amplifier, which optically isolates the inputs from the rest of the amplifier circuitry. See functional block diagram above.

OPERATING MODE SELECTION:

These modes can be selected by the DIP switches according to the chart in the functional block diagram:

- Current Mode
- Voltage Mode
- IR Compensation Mode
- Tachometer Mode

See section "G" for more information.

APPLICATION NOTE:

See section "G" for more information on analog position loop mode.

CURRENT LIMIT ADJUSTMENTS:

These amplifiers feature separate peak and continuous current limit adjustments.

The current limit adjusting Pot 2 adjusts both peak and continuous current limit at the same time. It has 12 active turns plus 1 inactive turn at each end and is approximately linear. Thus, to adjust the current limit, turn the potentiometer fully counter-clockwise, then turn clockwise to the appropriate value. If the desired limit is, for example, 15 amperes, and the servo amplifier peak current is 30 amperes, turn the potentiometer 7 turns clockwise from the fully counter-clockwise position.

Pin P1-9 is the input to the internal current amplifier stage. Since the output current is proportional to P1-9, the adjusted current limit can easily be observed at this pin. Note that a command signal must be applied to the reference inputs to obtain a reading on P1-9. The maximum peak current value equals 7.25V at this pin and the maximum continuous current value equals 3.63 V at this pin. If SW5=ON, peak rated amplifier current=7.25 V. if SW5=OFF, 1/2 peak rated amplifier current =7.25 V. Example: using the 30A20AC with SW5=ON, 30A=7.25 V and with SW5=OFF, 15A=7.25 V.

The actual current can be monitored at pin P1-8.

SW6 (DIP switch) will reduce the continuous current limit to 50% of the maximum value, when switched ON. SW5 (DIP switch) will reduce the current feedback (monitor) scaling by 50% thereby reducing both the peak and the continuous current limit by 50%, when switched OFF.

TYPICAL SYSTEM WIRING: See section "G".

ORDERING INFORMATION:

Models: 16A20ACX, 30A20ACX

X indicates the current revision letter.

MOUNTING DIMENSIONS: See page F-11.

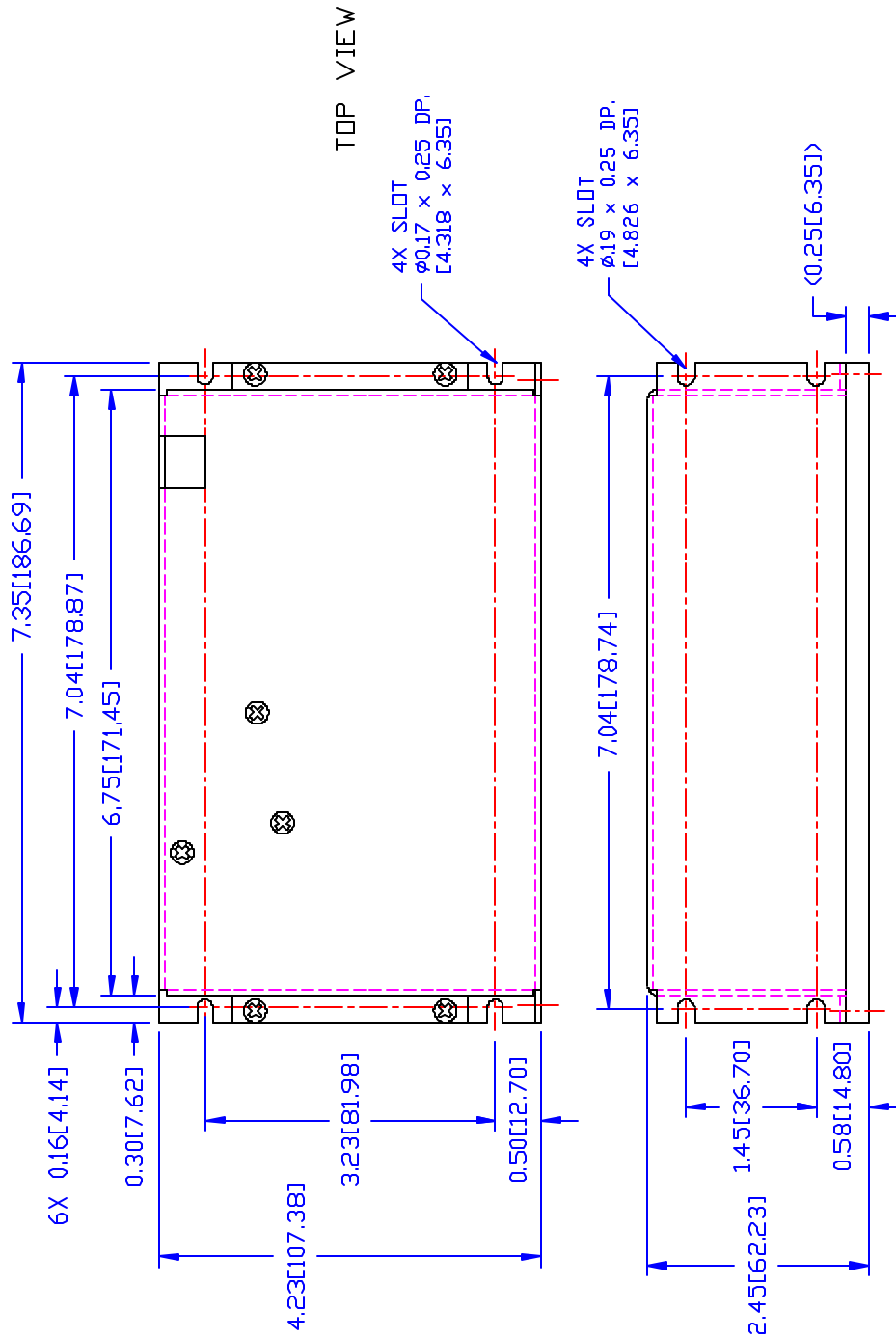

BACKSIDE VIEW

TOP VIEW

B	ADD BX25A20AC TO USED ON COLUMN	01/25/02	RB
A	UPDATE DWG. FORMAT & PICTORIAL	08/22/96	RB
REV	DESCRIPTION	DATE	BY



TITLE		MOUNTING DIMENSIONS	
B25A-AC & 30A-AC SERIES		SIZE	DWG. NO.
B		MB25AAC	
SCALE: NONE		SHT. 1 OF 1	

UNLESS OTHERWISE SPECIFIED, DIMENSIONS ARE IN INCHES	
TOLERANCES	
XX ± .010	DATE: 10/06/95
XXX ± .005	DATE:
DO NOT SCALE DRAWING	
DRAWN BY: R. BAUTISTA	DATE: 10/06/95
CHECK BY:	DATE:
DESIGN APPROVED:	DATE:
USED ON	
BX25A20AC SERIES	
BE25A20AC SERIES	
B25A20AC SERIES	
BD25A-AC SERIES	
30A-AC SERIES	

NOTE: DIMENSIONS IN [] ARE IN MM.